



NOVASAIL
NS360

Operating Manual

Contents

Introduction	3
Installation	4
Controls and display description	5
• Modes and sub-modes	5
Operations	6
• Switching power on and off	6
• Switching backlight on and off	7
• Switching modes and sub-modes	7
• Speed mode	8
• To reset the maximum speed	8
• To reset the trip distance	9
• Magnetic heading compass mode	9
• VMG mode	10
• To set and adjust the wind direction	10
• Wind shift indicator mode	11
• Memorization of the tack lines	11
• TIMER mode	13
• ROLL angle indicator mode	14
• Start line distance	14
• Waypoint mode	15
Advanced Operations	17
• SET mode	17
• Compass offset (angle of magnetic variation/declination)	19
• Boat offset	20
• Exit timer mode	21
• Exit mode of the start line	22
• Enable or disable the GPS functions	22
• Setting for the average time in SPA mode	23
• Enable or disable the race functions	23
• Firmware version	24
• Reset to factory compass calibration values	24
User calibration of the magnetic compass	25
Limited Warranty	34
Disclaimer	35

For the first time, with the *NS360*, you can find a speedo and a magnetic compass in one product, along with the all-essential race functions : wind shift indicator, VMG, direction, speed and distance to the waypoints, start line distance and race timer.



Compact (125 mm x 80 mm x 26 mm) and intuitive, the *NS360* is lighter (240 grams) than any existing system, wired or wireless. It is also waterproof and robust, being made of bombproof polycarbonate and anodized aluminium.

Powered with only one standard AA battery, the *NS360* gives sailors accurate and vital information for over 30 hours. It can be installed in minutes and there is no need to drill a hole in the hull or use a wired connection.

We hope you enjoy sailing with the *NS360*, and encourage you to read this manual thoroughly, to learn about the many features of your exciting new Novasail product.

Installation

The mounting location should be as far as possible from any magnetic objects to avoid any interference with the compass sensor.

The *NS360* should be mounted as close as possible to the vertical and horizontal planes.

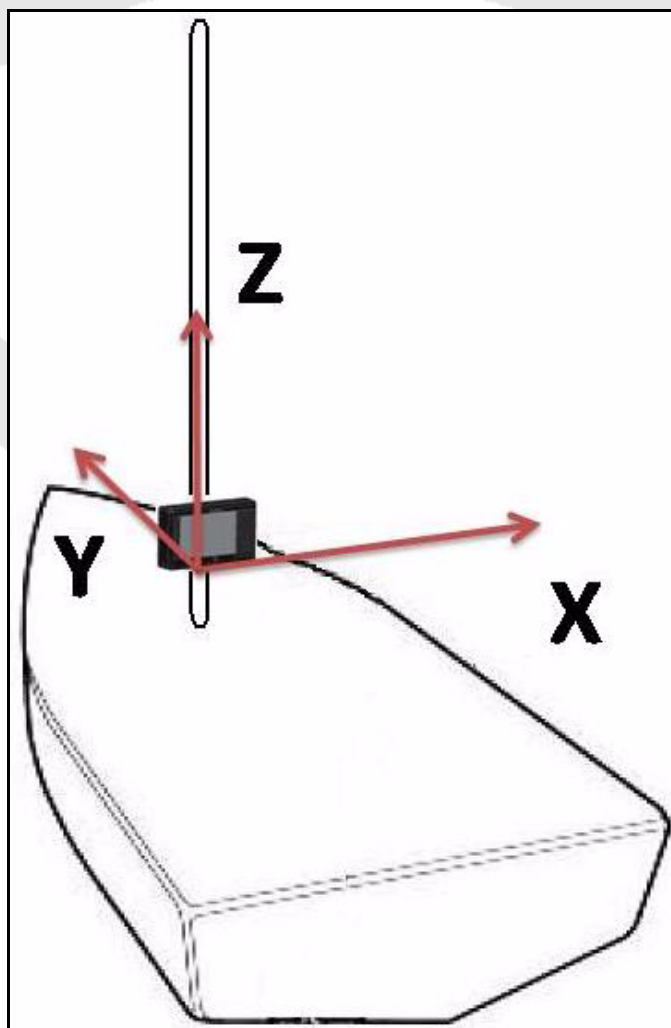

Note : Wherever you mount the *NS360*, it shouldn't be flush to any thick surface such as the hull, so that the sensitivity of the embedded GPS receiver is not affected.

Controls and display description

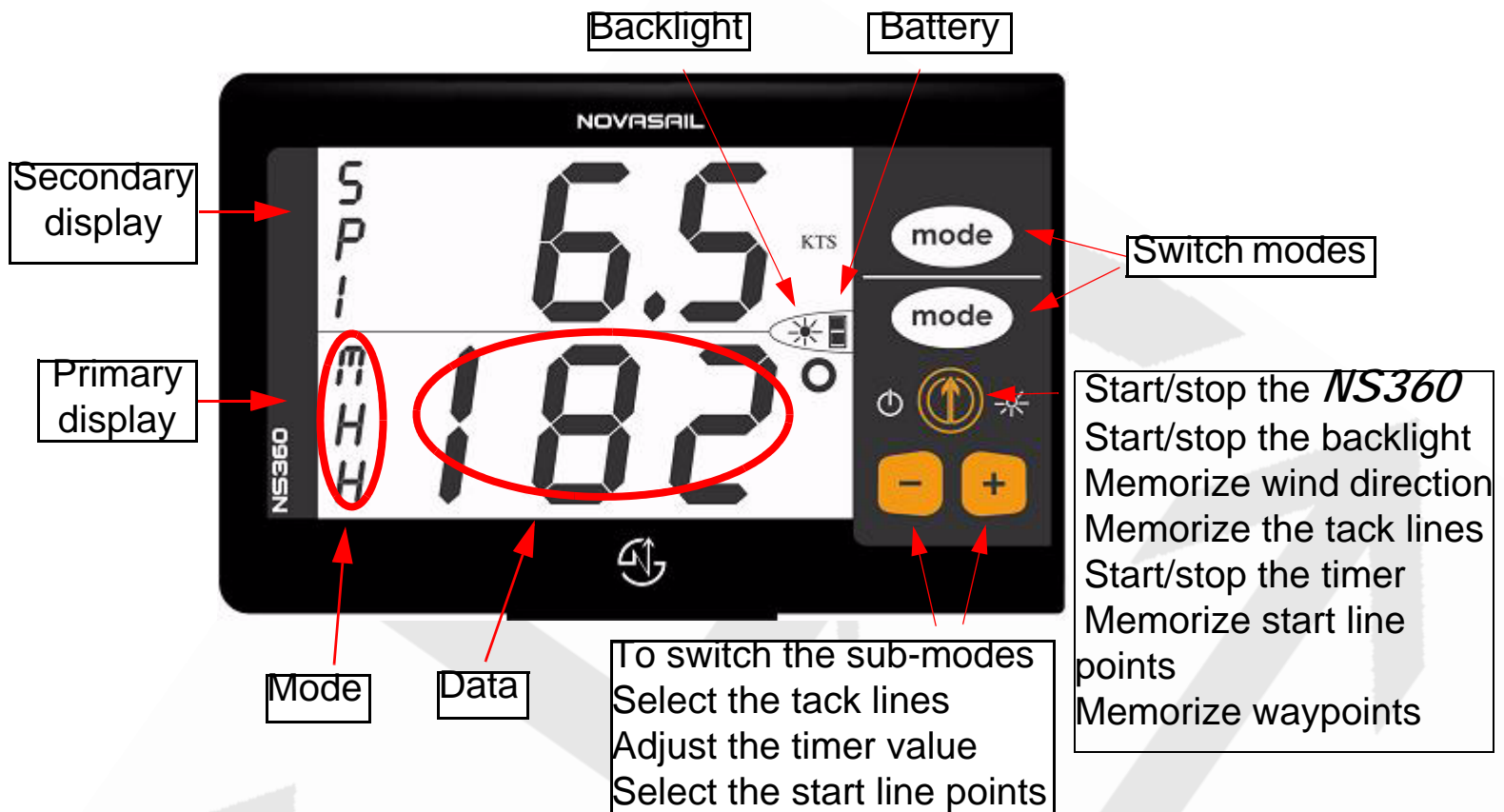

Modes and sub-modes

- Speed :
- **SPI** : Instant speed
 - **SPA** : Average speed
 - **SPM** : Maximum speed
 - **TRP** : Total distance
- Magnetic Heading :
- **MHH** : High sensitivity
 - **MHM** : Medium sensitivity
 - **MHL** : Low sensitivity
- Velocity Made Good :
- Wind Shift Indicator :
- TIMER :
- Roll angle indicator :
- Start Line Distance :
- Waypoints :
- **WP1 to WP9** : Waypoint 1 to 9

SP

MH

VMG

WIN

TIM

ROL

SLD



WP

Operations

Switching power on and off

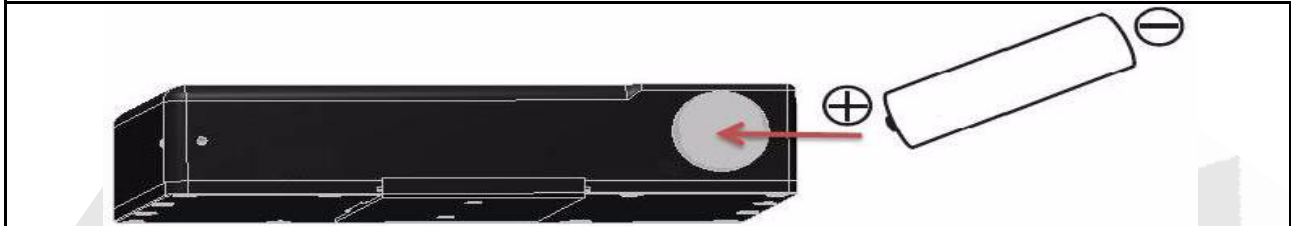
- Make sure the battery is installed with the correct polarity and has enough remaining power (positive pole inserted first)



- Press  to start the device. A beep will be emitted
- Press and hold  for more than 4 seconds until the screen displays OFF and the sequence “3”, “2”, “1” is finished. A beep will be emitted when the device turns off

The device will turn off automatically when it remains in the horizontal position for more than 3 minutes. A beep will be emitted 3 seconds before it turns off.

Note : If the device does not turn on, you need to check if the battery is fully charged, that the battery compartment is dry, and the polarity is correct.





Note : Until enough satellites are locked, the **NS360** is not ready to use. For the sub-modes SPI, SPA and TRP and the modes VMG, SLD and WP, the screen displays : ”---”. For the SPM sub-mode, the maximum value is displayed but blinking until readiness.

Note : Alkaline batteries should be used in order to result in a maximum lifespan of 30 hours. When using a disposable battery, it is also recommended to remove it if the device is not used for a prolonged period of time (in order to avoid a possible leakage inside the battery compartment).

If using rechargeable batteries, low self discharge rate battery types are preferred, because normal rechargeable batteries lose their stored energy more quickly. Recommended batteries are SANYO ENELoop, GP RECYKO+ or





UNIROSS HYBRIO. This kind of rechargeable battery will last for approximately 20 hours.

Switching backlight on and off

- Press and hold  for more than 1 second until the icon  is displayed on the screen. If the OFF sequence starts, simply release the button  before the sequence “3”, “2”, “1” is finished.
- To turn off the backlight, press and hold  for more than 1 second until the icon  disappears from the screen.

Note : When you press and hold the select button to switch on/off the backlight, you will not make any selection and therefore will not change any parameter.

Switching modes and sub-modes

- To have two different separate readings, first choose the mode and sub-mode required on the primary display by pushing  and then the arrows   for the sub-mode selection. Then, display the selected sub-mode on the secondary display using the  button.
- You are free to choose another mode/sub-mode on the primary display.

Note : Any sub-mode selection on the primary display will affect automatically the secondary display when both displays are in the same mode.

Operations

SSpeed mode

This mode provides the speed over ground of the boat as measured by the GPS receiver. Several speeds are available through the sub-modes : Instant, Average and Maximum as well as the trip distance.

- Use the arrows   to scroll the sub-modes.

SSpeed sub-modes

- **SPI** : **S**Speed **I**ntant

The Instant speed of the boat is displayed in knots (kts) with an accuracy of 0.1 knot. The minimum speed is 1 knot, and the maximum speed is 99.9 knots.

- **SPA** : **S**Speed **A**verage

This sub-mode provides the average speed of the boat during the past 2 to 10 seconds. This is particularly useful when sailing with big waves upwind or downwind with lots of speed changes.



Note : the average time can be adjusted thanks to the 'SPA' parameter in the 'SET' mode. Please refer to the "Setting for the average time in SPA mode : SPA", page 23 for more details.

- **SPM** : **S**Speed **M**aximum

The Maximum speed that the boat has reached since the last reset.

Note : For that sub-mode, don't forget to reset the maximum speed before your next sail begins to ensure the value displayed refers to the new trip.

To reset the maximum speed :



- Display SPM sub-mode in the lower screen using the arrows  
- Press 

- **TRP** : **TRiP** distance

The TRP mode displays the total distance made by the vessel since the last reset.

Note : For that sub-mode, don't forget to reset the trip before your next sail begins to ensure the value displayed refers to the new trip.

To reset the trip distance :

- Display TRP sub-mode in the lower screen using the arrows 
- Press 

Magnetic Heading compass mode

To win races you need to react to even small wind shifts. The **NS360** digital compass delivers precise and reliable heading information to help you to tack and jibe at the most suitable times.

The sensitivity of the compass can easily be adjusted to High, Medium or Low by scrolling through the sub-modes.

- Use the arrows  to scroll the sub-modes.

Sub-modes of the Magnetic Heading compass :

- **MHH** : **M**agnetic **H**eading **H**igh sensitivity

When sailing with light winds and flat seas, High sensitivity allows you to appreciate very small wind variation.

- **MHM** : **M**agnetic **H**eading **M**edium sensitivity

Medium sensitivity is more suitable for race boats under medium wind and sea conditions. Dinghy racers will appreciate this mode.

Operations

- **MHL** : **M**agnetic **H**eading **L**ow sensitivity



Under Low sensitivity more subtle variations due to big waves and sudden gusts are filtered.

Note : The magnetic variation of the area of use can be compensated by adjusting the compass offset. Please refer to the Advanced Operations “Compass offset”, page 19 for more details on the compass offset adjustment.

VMG mode

This mode provides the projected speed of the boat on the wind direction. The higher the value, the faster the vessel is going upwind or downwind. First, the wind direction must be set to display a VMG value on the data line. If no wind direction is set, the screen displays “---”. The VMG is displayed in knots (kts).

To set and adjust the wind direction in VMG mode

- Press  to capture the wind direction as the current heading value.
- Adjust the wind direction value with the arrows  

Note : Each time you press , the Magnetic Compass Heading is used as the wind direction.

Note : The wind direction may also be calculated from the the starboard and port tack lines if you have already set the values in the WIN mode. (See WIN mode, page 11)



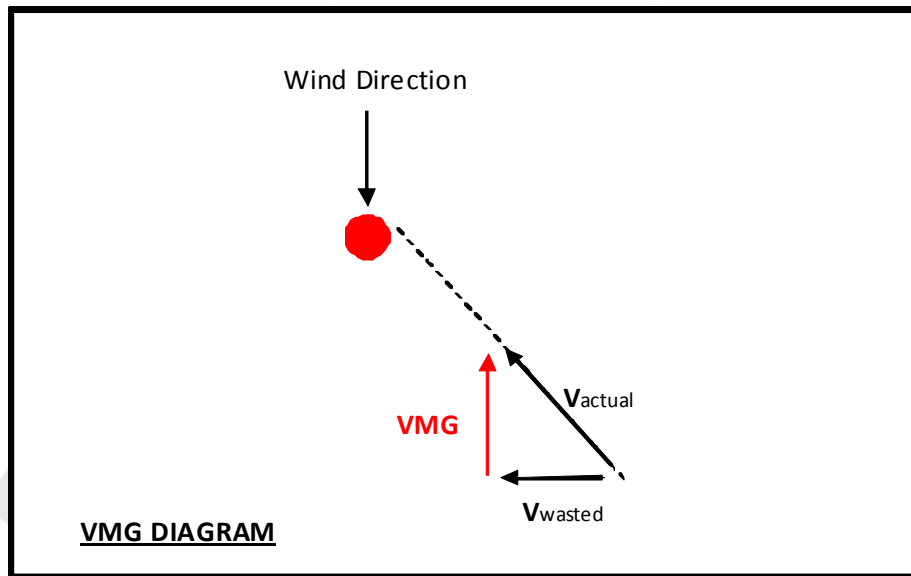

Note : When you memorize a wind direction in VMG mode, the tack lines in WIN mode are updated, assuming that the boat makes the same upwind angle on starboard and port.



WIND shift indicator mode

Used in Wind Shift Indicator (WIN) mode, the *NS360* displays numerical values of the wind shifts allowing an immediate and effortless interpretation. To use this mode, you need to memorize the tack lines on startboard and port.

Memorization of the tack lines :

- Sail upwind to your optimal VMG
- "D 1" is displayed on the data line of the lower screen
- Press  to use the current magnetic compass heading as the one of the tack line directions.
- The wind shift value is immediately displayed
- Press the arrows   to display "D 2" on the data line of the lower screen
- Sail upwind to your optimal VMG on the other tack line
- Press  to use the current magnetic compass heading as the other tack line direction

Operations

Note : The sequence of memorization of the tack lines on starboard and port is not defined. You can do starboard then port or vice versa.

The WIN mode displays an angle in degrees which corresponds to the difference between the tack line direction and the current magnetic compass heading of the boat. It displays 'H' (for Heading) in front of the value if the wind is heading, and 'L' (for Lift) in front of the value if the wind is lifting. When sailing upwind, you need to sail inside the lifts 'L'.

When sailing downwind, the WIN mode will display 'd' (for downwind) in front of the value of the deviation from the wind direction.

Note : The first tack line memorized is by default considered to be the starboard line. However, if this was the port tack line, the product will understand it automatically.

fig.1 WIN mode diagram when sailing on starboard

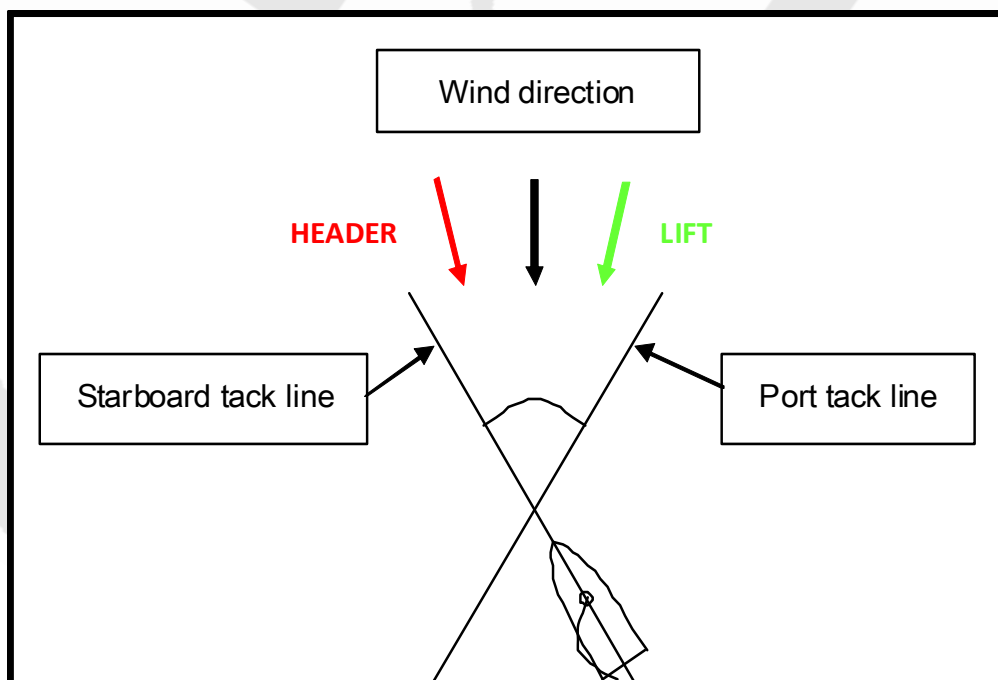

TIMER mode

This mode offers a countdown timer which can be set from 1 to 9 minutes.



When counting down, a short beep sounds :

- each minute until the last minute
- each ten seconds until 10 seconds
- each second until the start time

At the start time :



- a long beep sounds
- the timer starts counting the race duration in minutes and hours

Adjust, start and stop the TIMER :

- Adjust the timer value with the arrows  .
- Press  to start and stop the TIMER.

Resynchronize the TIMER to the nearest minute :

When the TIMER is running, at any time, you can resynchronize to the upper or lower minute

- Press the arrow  to resynchronize the value to the **upper** minute.
- Press the arrow  to resynchronize the value to the **lower** minute.

Note : The timer continues to count down until you press  to stop it, even during resynchronization. When stopped, the display blinks and the timer remains frozen.

Note : After the start, the timer will switch automatically to the mode defined in the SET mode. Please refer to the Advanced Operations “Exit Timer mode”, page 21 for more details. (The default value of the Exit Timer mode parameter is “SP” mode).

Note : When the down counter reaches '0:00' (whether the TIM mode is displayed or not), it will automatically force the exit of the 'SLD' mode (if displayed) as defined in the SET mode. Please refer to the Advanced Operations “Exit Start Line mode”, page 22 for more details.

Operations

Roll angle indicator mode : ROL

Used in Roll angle indicator (ROL) mode, the *NS350* displays the roll angle of the boat. The angle range can vary from 0 to 70 degrees; if the angle is greater than 70 degrees, the value blinks and remains unchanged.

Start Line Distance

Knowing the exact distance in meters to the start line gives a huge advantage in helping you start ahead of the fleet and even win the race. The *NS360* start line distance function is the most advanced on the market as it combines a 1 meter accuracy and a dynamic boat offset compensation calculated with the real boat magnetic heading to the start line.



The accuracy of the distance is 1 meter but it's safer to take a bigger margin. The maximum distance is 999 meters.

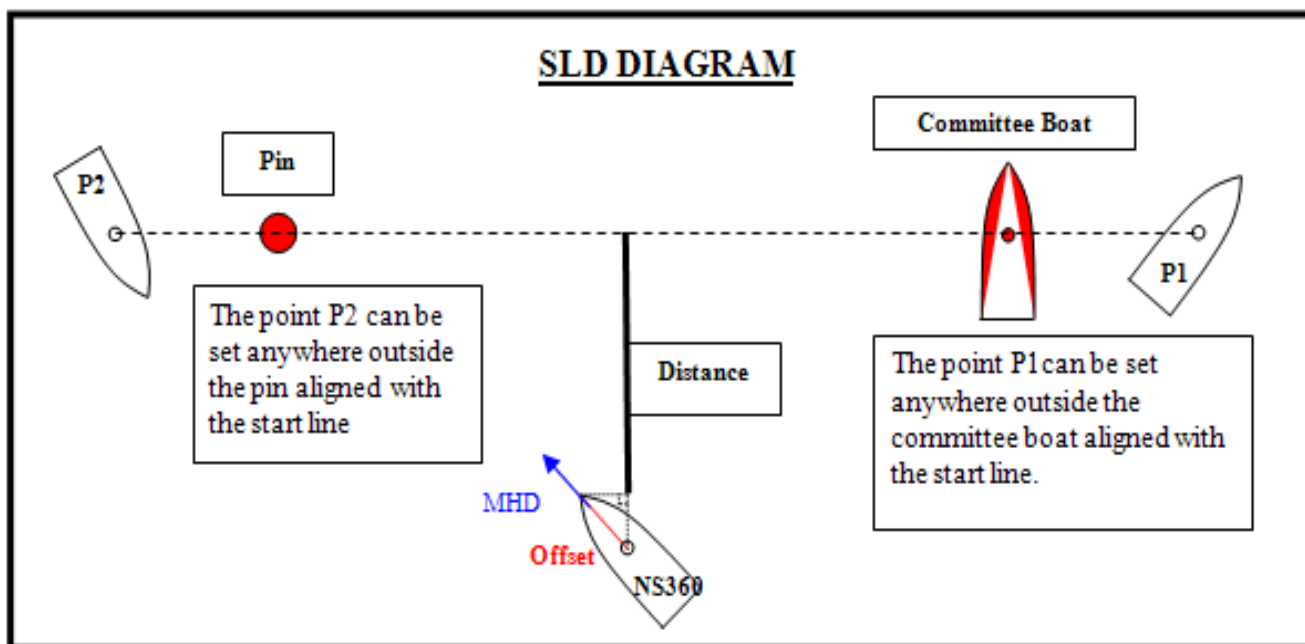

The start line consists of 2 points "P 1" and "P 2" that have to be aligned with the start line :

- P1 : Committee boat
- P2 : Pin



Memorize the start line points 'P 1' and 'P 2'

- 'P 1' is displayed on the data line of the lower screen.
- Press  when you reach the committee boat reference point.
- 'P 2' is now displayed on the data line of the lower screen.
- Press  when you reach the pin reference point.
- The distance in meter is now displayed on the data line.

Note : If the start line is modified by the committee, you may be required to re-enter one or both reference points. It can be done by pressing the arrows   to select the desired reference point and to memorize it by pressing .

Note : The distance from the front of the boat to the **NS360** is called the Boat Offset (BOF). Please refer to Advanced Operations "Boat offset", page 20 for more details on the boat offset adjustment.

Note : After the start, the Start Line Distance (SLD) will switch automatically to the mode defined in the SET mode. If the TIM mode is used and the down-counter reaches '0:00' (displayed or not), it will force automatically the exit of the 'SLD' mode. Please refer to the Advanced Operations "Exit Start Line mode", page 22 for more details. (The default value of the Exit Start Line mode parameter is "MH" mode).

WayPoint mode

Boats doing Island races are usually turning the same marks but in different orders. The waypoint mode has been made for those who are sailing island races and require information such as the direction, the speed and the distance to reach the selected pre-defined waypoint. Up to 9 waypoints can be memorized : WP1, WP2...to WP9. Each time a waypoint is selected, the direction, speed and distance to reach it are displayed sequentially every 4 seconds.

Operations

To use a waypoint

- By default, WP1 is displayed on the mode line.
- Press the arrows **-** **+** to select the required waypoint, from WP1 to WP9.
- The direction, speed and distance are displayed sequentially every 4 seconds.

To Memorize a waypoint

- Press the arrows **-** **+** to select the waypoint (from WP1 to WP9) that you want to overwrite.
- Press **📍** to memorize the current boat position into the selected waypoint.
- The direction, speed and distance to reach it are displayed sequentially every 4 seconds.

The waypoint speed displayed in knots is calculated using the waypoint position, the boat position, the boat speed and the heading.

The sign '+' means that you are approaching the waypoint and '-' that you are going in the opposite direction.

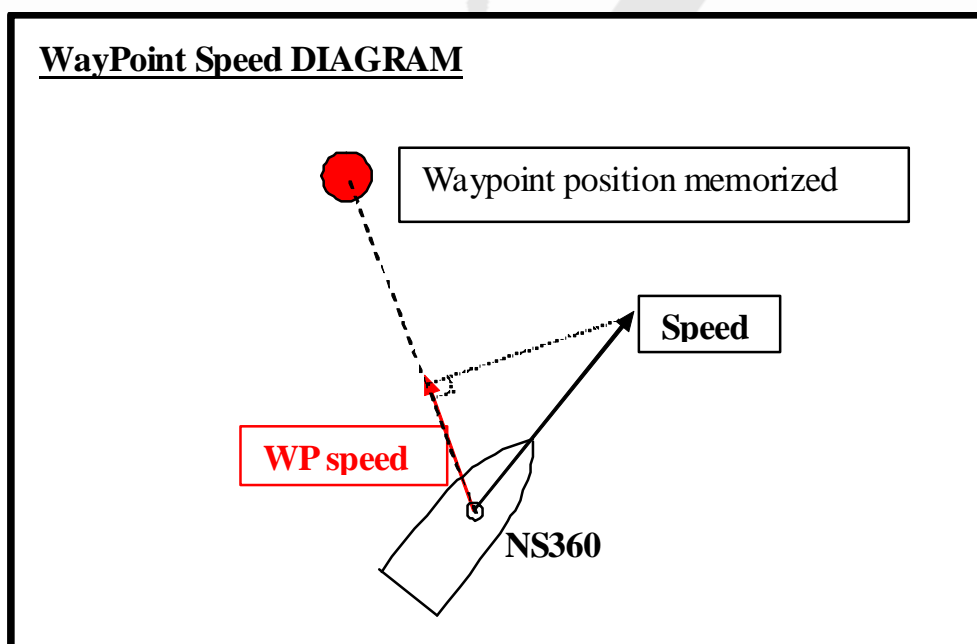





SET mode

The **SET** mode allows the adjustment of your *NS360* parameters sequentially as follows :

- Compass offset
- Boat offset
- Exit mode of the Timer
- Exit mode of the Start Line
- GPS module activation : on/off
- Race functions activation : on/off
- Reset the product to the factory default values
- Compass calibration

Note : GPS and Race functions can be turned off if your sailing class does not allow them. OFF is displayed when you select any mode using the GPS and/or Race functions.

To enter the SET mode :

- Press  and the upper screen  simultaneously. "SET" is displayed on the data line of the upper screen.
- Each parameter is displayed on the mode line of the lower screen.
- You can select the required value for each parameter using the arrows  .
- Press  to memorize the parameter value and switch to the next parameter.
- You exit the **SET** mode automatically after the last parameter is memorized.

Note : Each parameter is memorized when  is pressed and before the next parameter is displayed, except for reset and calibration.

Advanced Operations

Name	Display	Description
Compass Offset	COF	This allows to compensate the magnetic deviation. The default value is 0
Boat Offset	BOF	This is the length between the front of the boat and the <i>NS360</i> - default value 0, can be adjusted in 0.1 meter increments.
Exit Timer mode	ETI	- default alternate mode is the Speed mode - All other modes can be selected
Exit Start Line mode	ESL	- default alternate mode is the Magnetic Heading mode - All other modes can be selected
GPS activation	GPS	- ON - OFF (if your sailing class does not allow it during races)
Time setting for the average speed	SPA	The time for the computation of the average speed can be adjusted from 2 to 10 seconds. The default value is 3 seconds.
RACe functions activation	RAC	- ON - OFF (if your sailing class does not allow it during races)
Firmware version	VER	Firmware version number
RESet to factory default values	RES	- ON to retrieve factory values - OFF by default
Compass CaLibration	CAL	- ON to start - OFF by default







The *NS360* will automatically exit the SET mode upon completion of all parameters.

Note : You can also exit the SET mode anytime by switching off and on the product.

Compass offset (angle of magnetic variation/declination)

Because the angle of variation varies with respect to the geographic position, the *NS360* must be adjusted according to the specific location to achieve the maximum accuracy and synchronization between the GPS unit and the magnetic compass. The angle of variation is the actual angle observed between the true North geographic position and the actual North magnetic position.

To compensate for the magnetic variation, you need to adjust the parameter **COF** (Compass Offset) as follows :

- Switch off your *NS360*.
- Press  and the upper screen  simultaneously. 'SET' is displayed on the upper line of the display.
- COF (Compass Offset) is displayed on the mode line of the lower screen
- Use the arrows   to enter the required variation corrective value The first digit will display 'W' or 'E' for a west or a east variation, and the remaining 2 digits are the actual angle, adjustable from 0 to 45 degrees.
- Press  to store the value, BOF (Boat Offset) is now displayed.
- Go through all the parameters to exit the SET mode or press and hold  for more than 4 seconds until the device turns off.

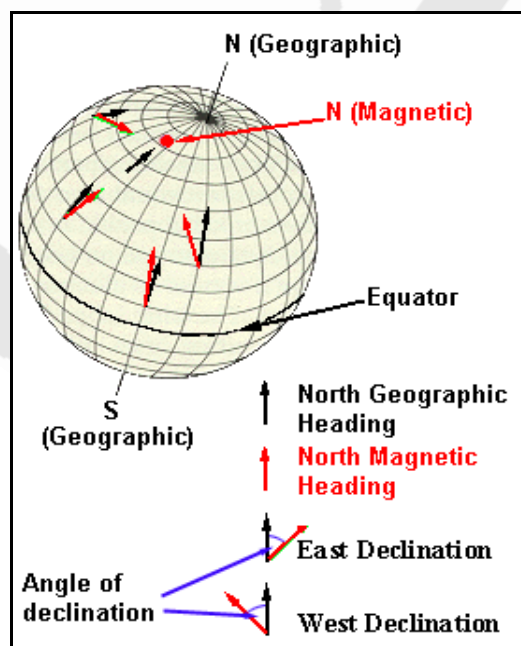

Advanced Operations

There are a number of resources available on the web that compute angles of variation for any location in the world. A “world Magnetic Model Calculator” is available from both the National Geophysical Data Center and the British Geological Survey :

- <http://www.ngdc.noaa.gov/seg/geomag/jsp/struts/calcDeclination>
- http://www.geomag.bgs.ac.uk/gifs/wmm_calc.html



Here’s some examples of magnetic variation for different geographic locations :

- Hong Kong : 2 degrees west
- Melbourne : 11 degrees east
- Marseille : 0 degree
- San Francisco : 14 degrees east





Boat offset

The boat offset corresponds to the distance from the front of the boat to the *NS360*. The remaining distance to the start line is calculated taking the boat offset and the current magnetic heading into account. The default value is 0, the maximum value is 99.9 meters and the increment is 0.1 meter.

Example : The real distance between the front of the boat to the *NS360* is 3.2 meters. You need to enter a boat offset equal to 3.2 meters. Then, considering that the *NS360* is 10 meters from the line. When you face the start line, the displayed remaining distance is equal to the 10-3.2 meters, 6 meters. However, using the magnetic heading of the boat, if you sail parallel to the line, then the display value is equal to the real distance between the line and the *NS360*, 10 meters.







- Switch off your *NS360*.
- Press  and the upper screen  simultaneously. 'SET' is displayed on the data line of the upper screen .

Advanced Operations

- Press  until BOF (Boat Offset) is displayed on the mode line of the lower screen.
- Use the arrows   to enter the length between the front of the boat to your *NS360*.
- Press  to store the value, ETI (Exit mode of the Timer) is now displayed.
- Go through all the parameters to exit the SET mode or press and hold  for more than 4 seconds until the device turns off.

Exit Timer mode : ETI

After the start, the Timer mode is not needed anymore, for this reason the *NS360* will switch automatically to the desired exit mode by simply setting the parameter ETI (Exit Timer mode) as follows :

- Switch off your *NS360*.
- Press  and the upper screen  simultaneously. 'SET' is displayed on the data line of the upper screen.
- Press  until ETI (Exit Timer mode) is displayed on the data line of the lower screen.
- Use the arrows   to select the desired exit mode for your *NS360*.
- Press  to store the value, ESL is now displayed.
- Go through all the parameters to exit the SET mode or press and hold  for more than 4 seconds until the device turns off.







Note : Only a mode (SP, MH, VMG, WIN, TIM, SLD, WP) and not a sub-mode (SPI, SPA, SPM, TRP, MHL, MHM, MHH, WP1, ...etc) can be memorized in the ETI parameter. However, the timer will switch automatically to the memorized mode and the sub-mode that you are currently using.

Note : The mode by default is SP (Speed mode).

Advanced Operations

Exit mode of the Start Line : ESL

After the start, the Start Line Distance (SLD) mode is not needed anymore, for this reason the *NS360* will switch automatically to the desired exit mode by simply setting the parameter ESL (Exit mode of the Start Line) as follows :

- Switch off your *NS360*.
- Press  and the upper screen  simultaneously. 'SET' is displayed on the data line of the upper screen.
- Press  until ESL (Exit mode of the Start Line) is displayed on the data line of the lower screen.
- Use the arrows   to select the desired exit mode for your *NS360*.
- Press  to store the value, GPS (GPS function parameter) is now displayed.
- Go through all the parameters to exit the SET mode or press and hold  for more than 4 seconds until the device turns off.



Note : The ESL parameter can only be a mode (SP, MH, VMG, WIN, TIM, SLD, WP) and not a sub-mode (SPI, SPA, APM, TRP, MHL, MHM, MHH, WP1, ...etc). However, the SLD will switch automatically to the memorized mode and the sub-mode that you are currently using.

Note : The mode by default is MH (Magnetic Heading mode).

Enable or disable the GPS functions : GPS

If your boat class does not allow electronic navigation aids and/or a speedometer, you are required to switch off all the functions issued with the embedded GPS module. When the GPS feature is turned off, the battery life is increased to approximately 150 hours. To check more details about the functions affected when switching off the GPS module, please refer to the table 1 : GPS and Race functions activation.

Setting for the average time in SPA mode : SPA

The SPA mode displays the average speed based on the average time adjustable from 2 to 10 seconds. Use the arrows   to select the desired time.

Enable or disable the RACe functions : RAC

If your boat class does not allow on board electronic navigation aids, you may be required to switch off the race functions. For more details about the modes affected when switching off the race functions, please refer to the table 1 : GPS and Race functions activation.

Table 1: GPS and Race functions activation

	GPS Off	RAC Off
Speed : SP (SPI/ SPA/ SPM/ TRP)	Off	On
Magnetic Heading : MH (MHH/ MHM/ MHL)	On	On
Velocity Made Good : VMG	Off	Off
Wind Shift Indicator : WIN	On	Off
Timer : TIM	On	On
Start Line Distance : SLD	Off	Off
Waypoint : WP (WP1/ WPx/ .../WP9)	Off	Off

Note : During normal usage, if you select a mode which has been disabled by setting off the GPS and/or the race functions, then 'OFF' will be displayed on the screen.

Advanced Operations

Firmware version : VER

The firmware version is displayed.

RESet to factory compass calibration values : RES

When set to ON and when the select key is pushed, the default factory calibration values of the compass are restored and the *NS360* is powered off automatically.

User CALibration of the magnetic compass : CAL

When set to ON and when the select key is pushed, the *NS360* enters a set of sub-menus to allow a user calibration of the magnetic compass. There are 10 sub-menus for which the user has to follow the sequence described below. To allow the maximum accuracy of the calibration procedure, it is recommended to perform this outdoors to avoid any magnetic disturbing fields. A wooden surface is highly recommended (eg a table) and it is necessary to ensure that there are no ferrous materials nearby (wrist watches should be removed).

To start with draw 2 perpendicular lines (X and Y axis) on a perfectly horizontal plan. On the lower screen of the display, the calibration sub-menu number is displayed. There are 10 steps to follow in order to complete the calibration of your *NS360*. Upon completion of the sequence, the *NS360* will memorize the new values and shut down automatically. If the *NS360* is shut down during the calibration, nothing will be memorized.

Note : Whenever necessary, the factory calibration values can be restored at any time by setting the RES menu to ON in the SET mode.

- Step 1 : '1' is displayed on the lower screen. The *NS360* must be oriented as follows :

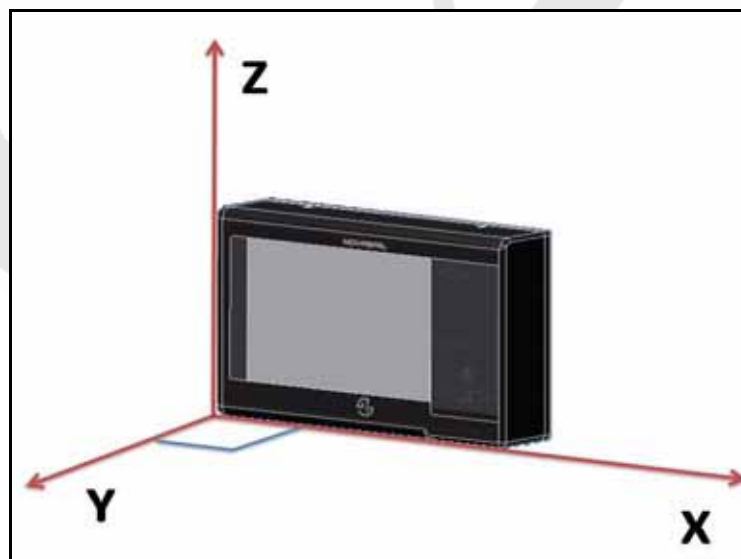

Push the select key when ready. The *NS360* will enter the calibration along the axis. After a few seconds, 3 beeps will be emitted to notify the end of step 1.

Calibration

- Step 2 : '2' is now displayed on the lower screen. The *NS360* must be oriented as follows :

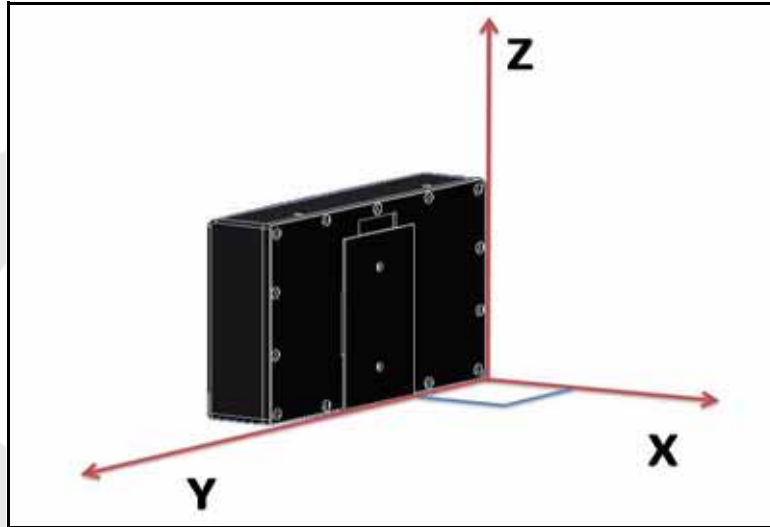

Push the select key when ready. The *NS360* will enter the calibration along the axis. After a few seconds, 3 beeps will be emitted to notify the end of step 2.

- Step 3 : '3' is now displayed on the lower screen. The *NS360* must be oriented as follows :

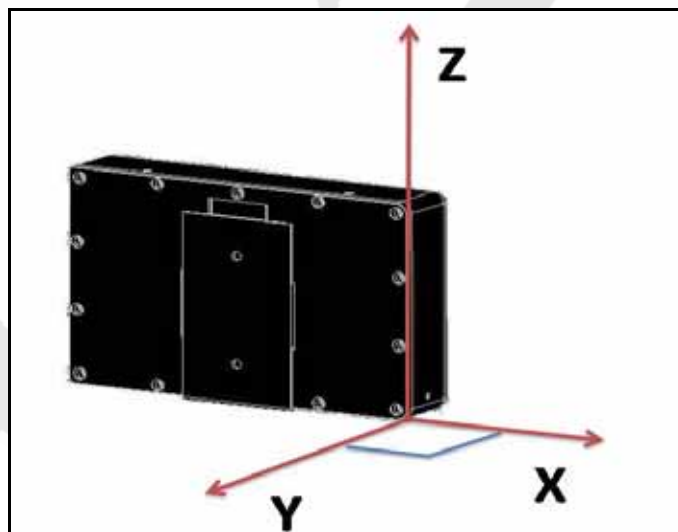

Push the select key when ready. The *NS360* will enter the calibration along the axis. After a few seconds, 3 beeps will be emitted to notify the end of step 3.

- Step 4 : '4' is now displayed on the lower screen. The *NS360* must be oriented as follows :

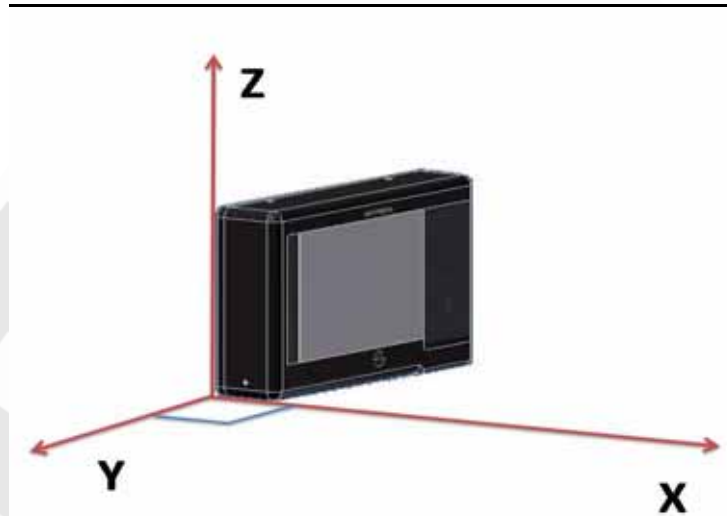

Push the select key when ready. The *NS360* will enter the calibration along the axis. After a few seconds, 3 beeps will be emitted to notify the end of step 4.

- Step 5 : '5' is now displayed on the lower screen. The *NS360* must be oriented as follows :

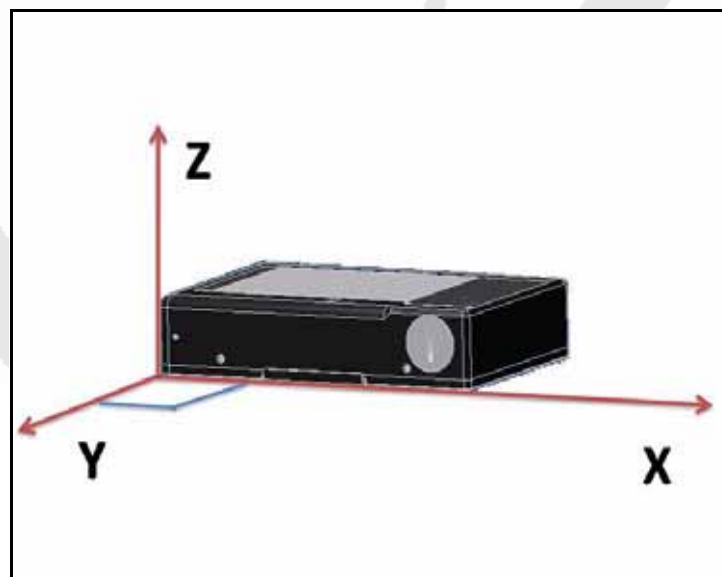

Push the select key when ready. The *NS360* will enter the calibration along the axis. After a few seconds, 3 beeps will be emitted to notify the end of step 5.

Calibration

- Step 6 : '6' is now displayed on the lower screen. The *NS360* must be oriented as follows :

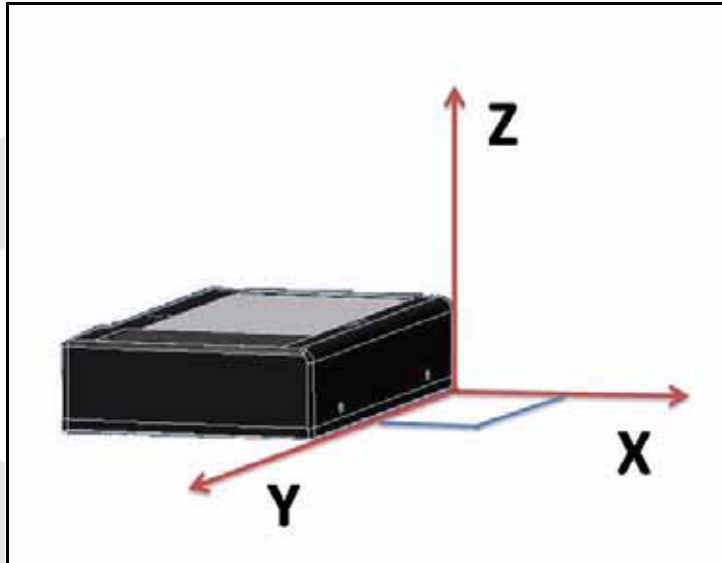

Push the select key when ready. The *NS360* will enter the calibration along the axis. After a few seconds, 3 beeps will be emitted to notify the end of step 6.

- Step 7 : '7' is now displayed on the lower screen. The *NS360* must be oriented as follows :

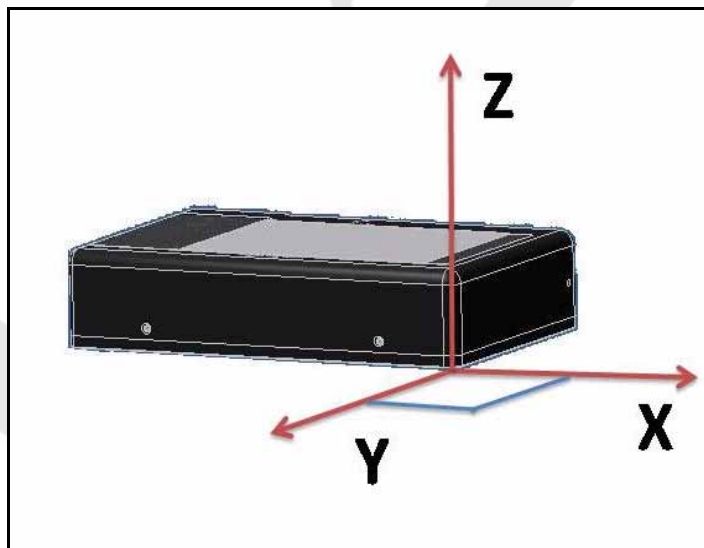

Push the select key when ready. The *NS360* will enter the calibration along the axis. After a few seconds, 3 beeps will be emitted to notify the end of step 7.

- Step 8 : '8' is now displayed on the lower screen. The *NS360* must be oriented as follows :

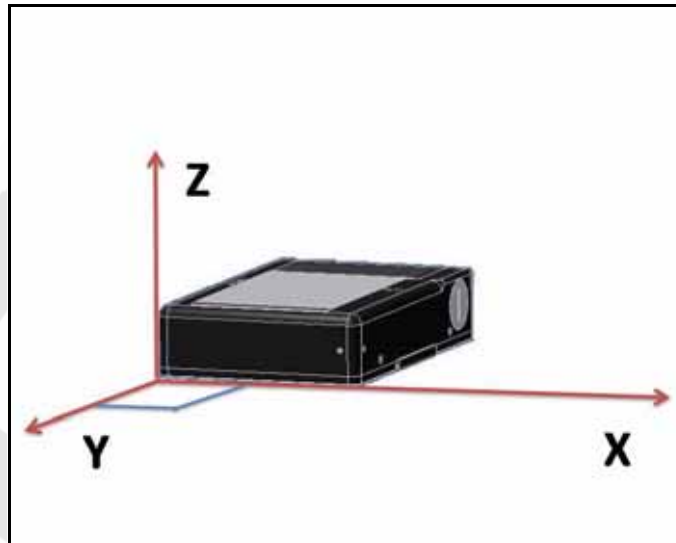

Push the select key when ready. The *NS360* will enter the calibration along the axis. After a few seconds, 3 beeps will be emitted to notify the end of step 8.

- Step 9 : '9' is now displayed on the lower screen. The *NS360* must be oriented as follows :

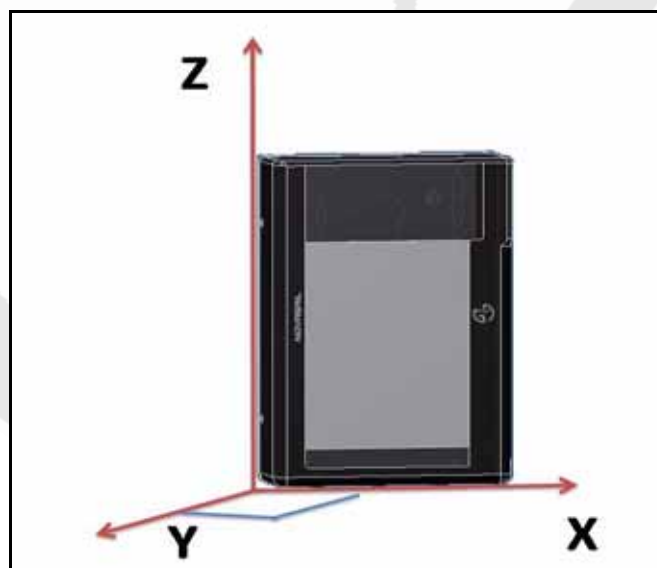

Push the select key when ready. The *NS360* will enter the calibration along the axis. After a few seconds, 3 beeps will be emitted to notify the end of step 9.

Calibration

- Step 10 : '10' is displayed on the lower screen. The *NS360* must be oriented as follows :

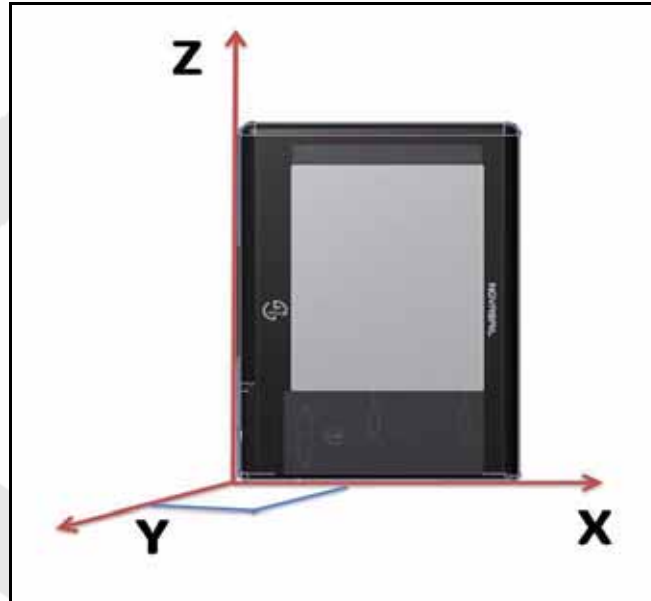

Push the select key when ready. The *NS360* will enter the calibration along the axis. After a few seconds, 3 beeps will be emitted to notify the end of step 10.

The *NS360* will store the new values and switch off automatically.



Document History

Version 1.0: First version

Version 1.1: 1/1/2010

- Updated pictures
- Updated SPA submode description in SP mode
- Added ROL mode
- Added SPA setting in SET mode
- Added Firmware version (VER) setting in SET mode
- Updated TIM mode description (force SLD exit mode when down counter reaches '0:00')
- Updated SLD mode description



Limited warranty

This product meets or exceeds all of Novasail's rigorous quality controls and inspection standards. Complete services will be provided in accordance with the statement of warranty set forth below if any manufacturing defect or natural failure occurs within the warranty period.

Warranty Terms and Conditions

- If any defect arises under normal conditions of use within the warranty period, our customer service center or specified partner will provide the required repair services at no charge, or legally applicable services according to the appropriate consumer protection laws and regulations of the country in which the product was purchased by the warranty holder.
- The product has to be registered using the online service available on the Novasail web site: www.nova-sail.com
- Please submit the proof of purchase (Invoice) when requesting service.
- The actual cost of repair may be charged to the customer or the performance of warranty service may be rendered impossible, even within the warranty period, under the following circumstances:
 - Product failure caused by accident or carelessness
 - Disassembly or modification for purposes other than it was originally intended for
 - Failure caused by a fire, earthquake or flood
 - Damage/failure caused by an impact
 - Failure caused by inappropriate services performed by anyone other than Novasail's customer service center or one of Novasail's service specified partners
- For assistance in obtaining service, please contact Novasail service center:

E-mail: contact@nova-sail.com
www.nova-sail.com

DISCLAIMER

Information in this document is provided solely in connection with NOVASAIL LTD products. NOVASAIL LTD reserves the right to make changes, corrections, modifications or improvements to this document and the products described herein at any time, without notice.

All NOVASAIL LTD products are sold pursuant to NOVASAIL LTD's terms and conditions of sale.

Purchasers are solely responsible for the choice, selection and use of the NOVASAIL LTD products described herein, and NOVASAIL LTD assumes no liability whatsoever relating to the choice, selection or use of the NOVASAIL LTD products described herein.

UNLESS OTHERWISE SET FORTH IN NOVASAIL LTD'S TERMS AND CONDITIONS OF SALE, NOVASAIL LTD DISCLAIMS ANY EXPRESS OR IMPLIED WARRANTY WITH RESPECT TO THE USE AND/OR SALE OF NOVASAIL LTD PRODUCTS, INCLUDING WITHOUT LIMITATION IMPLIED WARRANTIES OF MERCHANTABILITY OR FITNESS FOR A PARTICULAR PURPOSE (AND THEIR EQUIVALENTS UNDER THE LAWS OF ANY JURISDICTION).

UNLESS EXPRESSLY APPROVED IN WRITING BY AN AUTHORIZED NOVASAIL LTD REPRESENTATIVE, NOVASAIL LTD PRODUCTS ARE NOT RECOMMENDED, AUTHORIZED OR WARRANTED FOR USE IN MILITARY, AIR CRAFT, SPACE, LIFE SAVING, OR LIFE SUSTAINING APPLICATIONS, NOR IN PRODUCTS OR SYSTEMS WHERE FAILURE OR MALFUNCTION MAY RESULT IN PERSONAL INJURY, DEATH, OR SEVERE PROPERTY OR ENVIRONMENTAL DAMAGE.

Resale of NOVASAIL LTD products with provisions different from the statements and/or technical features set forth in this document shall immediately void any warranty granted by NOVASAIL LTD for the NOVASAIL LTD product or service described herein and shall not create or extend in any manner whatsoever, any liability of NOVASAIL LTD.





© 2010 NOVASAIL - All rights reserved
www.nova-sail.com