



NOVASAIL

NS360+

Operating Manual

Contents

Introduction	4
Installation	5
Controls and display description	6
• Modes and sub-modes	6
• Controls and display description	6
Operations	7
• Switching power on and off	7
• Switching backlight on and off	8
• Activate a line, Switching modes and sub-modes	8
• Speed mode	9
• To reset the maximum speed	9
• To reset the trip distance	10
• To set and adjust the wind direction in VMG mode	10
• Current GPS coordinates	11
• Central Bar graph	11
• Magnetic heading compass mode	12
• Sub-modes of the Magnetic Heading compass	12
• True Wind direction	13
• TIMER mode	15
• Start line distance	16
• Waypoint mode: Wxx	17
Advanced Operations	19
• Mode WAY	19
• SET mode	20
• Advanced or simple user interface selection	22
• Timing display of the direction in Wxx mode	23
• Timing display of the speed in Wxx mode	23
• Timing display of the distance in Wxx mode	23
• Angle of magnetic variation/declination	23
• Device offset	25
• Boat offset	25
• Exit timer mode	26
• Exit mode of the start line	26
• LCD contrast adjustment	27
• Enable or disable the Bar graph	27

Contents

• Bar graph resolution.....	27
• Enable or disable the GPS functions	28
• Firmware version	28
• Reset to factory compass calibration values.....	29
User calibration of the magnetic compass	30
Limited Warranty	37
Disclaimer	38

Introduction

Thanks to its advanced race functions, its GPS speedo and its magnetic compass, the *NS360* has built a solid reputation within the global racing community over the last three years, winning world champion places in the J80, Open 5.70, Xterm40 Asian Tour etc.

The new version of the *NS360* offers a more sensitive speedo, a new screen with a better contrast and readability, a new true wind direction function and a central bar graph displaying the wind shifts.

While keeping its compact (125 mm x 80 mm x 26 mm) and light (240 grams) casing, the *NS360+* is now even easier to use with better performance thanks to two fully independent data lines.

Still powered with only one standard AA battery, the *NS360+* can now be used over 36 hours.

Additionally, installed in minutes the new support gives a much better safety lock.

We hope you enjoy sailing with the *NS360+*, and encourage you to read this manual thoroughly, to learn about the many features of your exciting new Novasail product.

The mounting location should be as far as possible from any magnetic objects to avoid any interference with the compass sensor.

The *NS360+* should be mounted as close as possible to the vertical and horizontal planes.

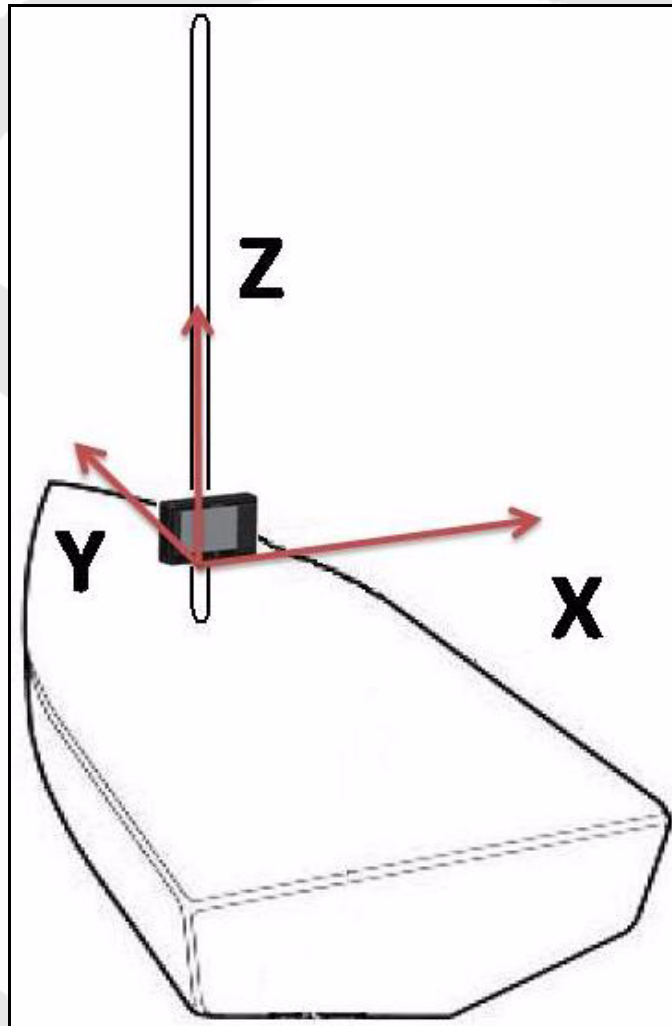

Note: Wherever you mount the *NS360+*, it shouldn't be flush to any thick surface such as the hull, so that the sensitivity of the embedded GPS receiver is not affected.

Note: If your *NS360+* isn't facing the same direction as the boat, you can compensate this difference with the parameter 'DEV OFS'. Please refer to the "Device offset: DEV OFS", page 25 for more details

Controls and display description

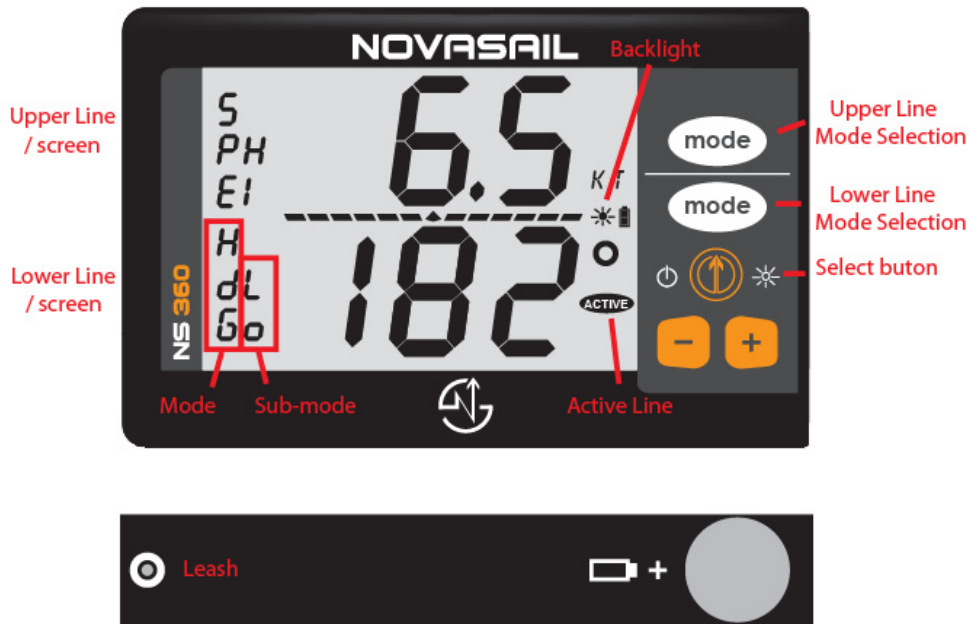

Modes and sub-modes

Speed:

- **Hi**: High sensitivity
- **Md**: Medium sensitivity
- **Lo**: Low sensitivity
- **MAX**: Maximum speed
- **TRP**: Total distance
- **VMG**: Velocity Made Good

Magnetic Heading:

- **Hi**: High sensitivity
- **Md**: Medium sensitivity
- **Lo**: Low sensitivity
- **ROL**: Roll angle indicator

True Wind Direction:

TIMER:

Start Line Distance:

Waypoints:

- **W00 to W99**: Waypoint 0 to 99

Current GPS coordinates:

SPE

HDG

WIN

TIM

SLD



Wxx

Latitude & Longitude

Switching power on and off

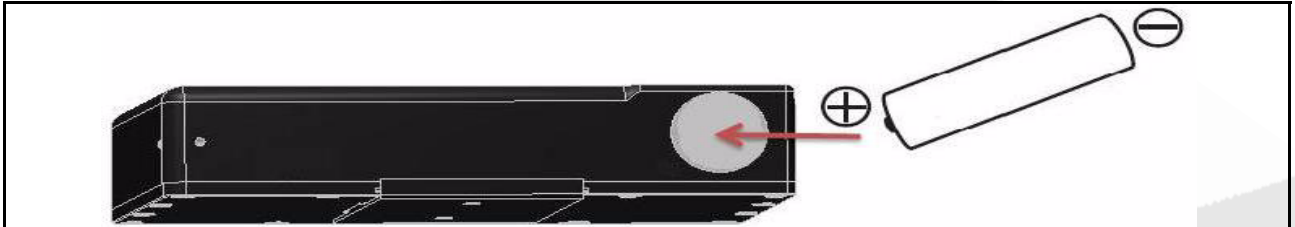
- Make sure the battery is installed with the correct polarity and has enough remaining power (positive pole inserted first).



- Press  to start the device. A beep will be emitted.
- Press and hold  for more than 4 seconds until the screen displays OFF and the sequence “3”, “2”, “1” is finished. A beep will be emitted when the device turns off.

The device will turn off automatically when it remains in the horizontal position for more than 3 minutes. A beep will be emitted 3 seconds before it turns off.

Note: If the device does not turn on, you need to check if the battery is fully charged, that the battery compartment is dry, and the polarity is correct.

Note: If the battery is almost discharged, the GPS functions are automatically deactivated (“OFF” is displayed) in order to save power. Only the functions linked to the magnetic compass are activated and the battery indicator blinks.





Note: Until enough satellites are locked, the NS360+ is not ready to use. For the modes SPE, VMG, SLD and Wxx, the screen displays: “---”. For the MAX speed sub-mode, the maximum value is displayed but blinking until readiness.

Note: Alkaline batteries should be used in order to result in a maximum lifespan of 36 hours. When using a disposable battery, it is also recommended to remove it if the device is not used for a prolonged period of time (in order to avoid a possible leakage inside the battery compartment).

Operations







If using rechargeable batteries, low self discharge rate battery types are preferred, because normal rechargeable batteries lose their stored energy more quickly. Recommended batteries are SANYO ENELOOP, GP RECYKO+ or UNIROSS HYBRIO. This kind of rechargeable battery will last for approximately 25 hours.

Switching backlight on and off

- Press and hold  for more than 1 second until the icon  is displayed on the screen. If the OFF sequence starts, simply release the button  before the sequence “3”, “2”, “1” is finished.
- To turn off the backlight, press and hold  for more than 1 second until the icon  disappears from the screen.

Note: When you press and hold the select button to switch on/off the backlight, you will not make any selection and therefore will not change any parameter.

Activate a line, Switching modes and sub-modes

- A line is 'ACTIVE' when the icon  appears inside. To activate a line, you need to push  once in front of the chosen line. The icon  appears.
- After activating a line, choose the mode and sub-mode required on the 'ACTIVE' line by pushing  and then the arrows   for the sub-mode selection.
- You are free to choose any mode/sub-mode on each line independantly.

Speed mode: SPE

This mode provides the speed over ground of the boat as measured by the GPS receiver. The sub-modes provide several speed resolutions, the trip distance and the VMG. The boat speed is displayed in knots (kts) with an accuracy of 0.1 knot. The minimum speed is 0.5 knot.

- Use the arrows   to scroll the sub-modes.

Speed sub-modes

- **Hi: High sensitivity**

The high sensitivity speed allows a very sensitive reading of any speed variation.

- **Md: Medium sensitivity**

This sub-mode provides an average speed of the boat over a short period of time. This is particularly useful when sailing with big waves upwind or downwind.

- **Lo: Low sensitivity**



This sub-mode provides an average speed of the boat over a longer period of time. This is particularly useful in rough conditions with lots of speed changes.

- **Max: Speed MAXimum**

The maximum speed that the boat has reached since the last reset.

Note: For the 'Max' sub-mode, don't forget to reset the maximum speed before your next sail begins to ensure the value displayed refers to the new trip.

To reset the maximum speed:

- Display MAX sub-mode in the lower screen using the arrows  
- Press 



Operations

- **TRP: TRiP** distance

The TRP mode displays the total distance made by the vessel since the last reset.

Note: For the 'TRP' sub-mode don't forget to reset the trip before your next sail begins to ensure the value displayed refers to the new trip.



To reset the trip distance:

- Display TRP sub-mode in the lower screen using the arrows  
- Press 

- **VMG mode**

This sub-mode provides the projected speed of the boat on the reference direction. According to your needs, the reference direction may be the wind direction or the direction to the upwind mark. The VMG is displayed in knots (kts).

To set and adjust the wind direction in VMG mode

- Press  to capture the wind direction as the current heading value.
- Adjust the wind direction value with the arrows  

Note: Each time you press , the Magnetic Compass Heading is used as the wind direction. The VMG speed sensitivity is adjustable (Hi/Md/Lo) by setting the sensitivity of the speed in SPE mode on the complementary line.

Note: The wind direction memorixxed will be used in the WIN mode.

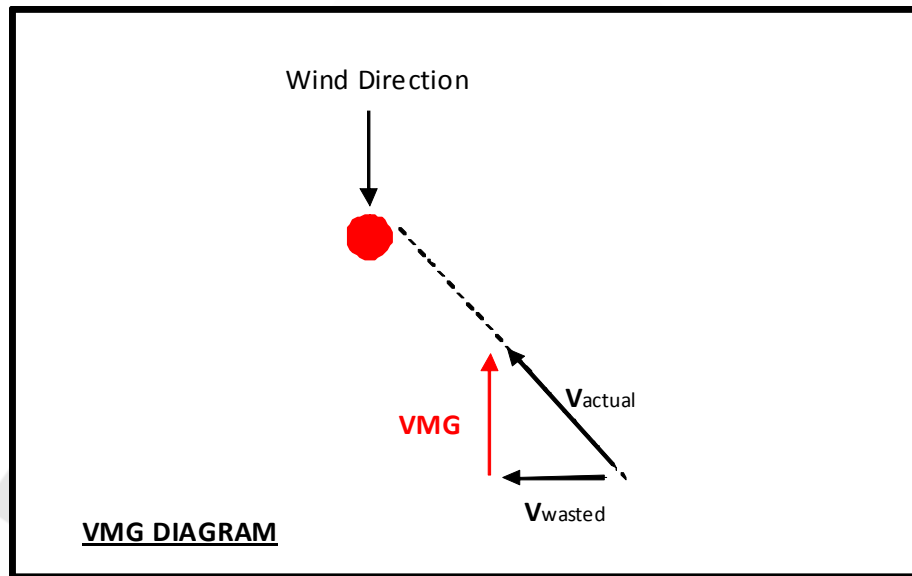

Current GPS coordinates

This mode allows the latitude and longitude of the current position to display (in degrees, decimal minutes). To activate this mode, you need to press simultaneously the **-** and **+** buttons. The latitude is displayed on the upper line and the longitude on the lower line.

Press **mode** to exit this mode.

Central Bar graph

The central bar graph allows the visualization of the heading variations. After a tack or a jibe, during the average heading calculation, the bar graph displays:



Once calculated, the average heading is used as the reference to display the variations in degrees.

Operations

For example  means that the current heading is 3 degrees starboard compared to the average reference heading, with a 1 degree value for each segment. *Please refer to the Advanced Operations “Bar graph resolution: BAR GRA RES”, page 27 for more details.*

Magnetic Heading compass mode: HDG

To win races you need to react to even small wind shifts. The *NS360+* digital compass delivers precise and reliable heading information to help you to tack and jibe at the most suitable times.

The sensitivity of the compass can easily be adjusted to High, Medium or Low by scrolling through the sub-modes.

- Use the arrows   to scroll the sub-modes.

Sub-modes of the Magnetic Heading compass:

- **Hi: High** sensitivity

When sailing with light winds and flat seas, high sensitivity allows you to appreciate very small wind variation.

- **Md: Medium** sensitivity

Medium sensitivity is more suitable for race boats under medium wind and sea conditions. Dinghy racers will appreciate this mode.

- **Lo: Low** sensitivity

Under low sensitivity more subtle variations due to big waves and sudden gusts are filtered.

Note: The magnetic variation of the area of use can be compensated by adjusting the magnetic variation parameter. Please refer to the Advanced Operations “Angle of magnetic variation/declination: MAG VAR”, page 23 for more details on the compass offset adjustment.

- **ROL:** Roll angle indicator mode



Used in Roll angle indicator (ROL) mode, the *NS360+* displays the roll angle of the boat. The angle range can vary from 0 to 70 degrees; if the angle is greater than 70 degrees, the value blinks and remains unchanged.

Note: The roll angle displayed is based on the NS360+ roll angle.

True Wind direction: WIN

Used in True Wind direction Indicator (WIN) mode, the *NS360+* displays the numerical value of the wind direction allowing an immediate and effortless reading. To use this mode, you need to calibrate a reference wind direction.

Setting of the reference wind direction:

- Sail upwind until heading into the wind.
- Press  to use the current magnetic compass heading as the wind direction.
- The wind direction value is immediately displayed.
- Press the arrows   to adjust the value.

Operations

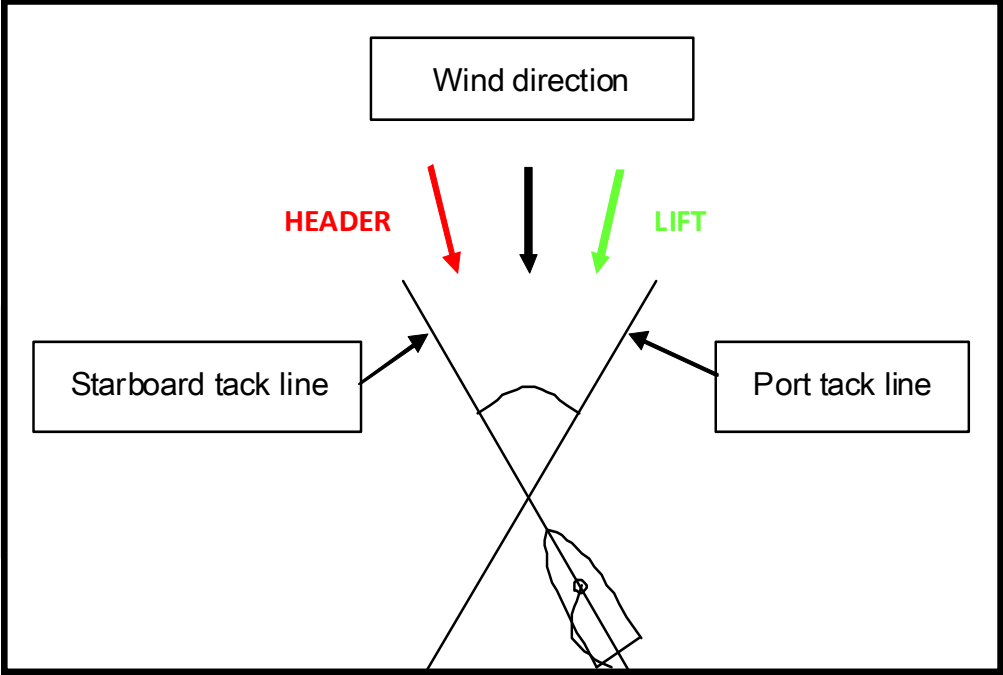

TIMER mode: TIM



This mode offers a countdown timer which can be set from 1 to 9 minutes. When counting down, a short beep sounds:

- each minute until the last minute
- each ten seconds until 10 seconds
- each second until the start time

At the start time:



- a long beep sounds
- the timer starts counting the race duration in minutes and hours

Adjust, start and stop the TIMER:

- Adjust the timer value with the arrows  .
- Press  to start and stop the TIMER.

Resynchronize the TIMER to the nearest minute:

When the TIMER is running, at any time, you can resynchronize to the upper or lower minute

- Press the arrow  to resynchronize the value to the **upper** minute.
- Press the arrow  to resynchronize the value to the **lower** minute.

Note: The timer continues to count down until you press  to stop it, even during resynchronization. When stopped, the display blinks and the timer remains frozen.

Note: After the start, the timer will switch automatically to the mode defined in the SET mode. Please refer to the Advanced Operations “Exit Timer mode: EXI TIM”, page 26 for more details. (The default value of the Exit Timer mode parameter is “SPE” mode).

Note: When the down counter reaches '0:00' (whether the TIM mode is displayed or not), it will automatically force the exit of the 'SLD' mode (if

Operations

displayed) as defined in the SET mode. Please refer to the Advanced Operations “Exit mode of the Start Line: EXI SLD”, page 26 for more details.

Start Line Distance: SLD

Knowing the exact distance in meters to the start line gives a huge advantage in helping you start ahead of the fleet and even win the race. The *NS360+* start line distance function is the most advanced on the market as it combines a 1 meter accuracy and a dynamic boat offset compensation calculated with the real boat magnetic heading to the start line.



The accuracy of the distance is 1 meter but it's safer to take a bigger margin. The maximum distance is 999 meters.

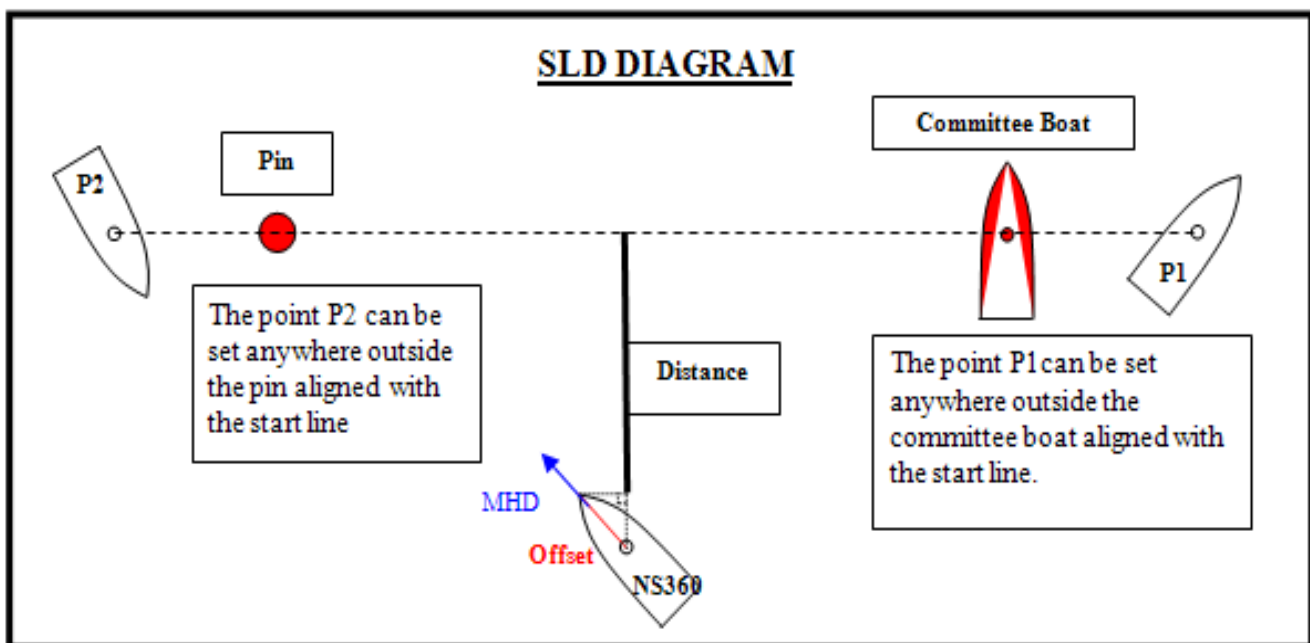

The start line consists of 2 points “P 1” and “P 2” that have to be aligned with the start line:

- P1: Committee boat
- P2: Pin



Memorize the start line points 'P 1' and 'P 2'

- 'P 1' is displayed on the data line.
- Press  when you reach the committee ('COM') boat reference point.
- 'P 2' is now displayed on the data line.
- Press  when you reach the pin ('PIN') reference point.
- The distance in meter is now displayed on the data line.

Note: If the start line is modified by the committee, you may be required to re-enter one or both reference points. It can be done by pressing the arrows   to select the desired reference point and to memorize it by pressing .

Note: The distance from the front of the boat to the NS360+ is called the Boat Offset (BOA OFS). Please refer to Advanced Operations "Boat offset: BOA OFS", page 25 for more details on the boat offset adjustment.

Note: After the start, the Start Line Distance (SLD) will switch automatically to the mode defined in the SET mode. If the TIM mode is used and the down-counter reaches '0:00' (displayed or not), it will force automatically the exit of the 'SLD' mode. Please refer to the Advanced Operations "Exit mode of the Start Line: EXI SLD", page 26 for more details. (The default value of the Exit Start Line mode parameter is "HDG" mode).

Waypoint mode: Wxx

Boats doing Island races are usually turning the same marks but in different orders. The waypoint mode has been made for those who are sailing island races and require information such as the direction, speed and distance to reach the selected pre-defined waypoint. Up to 100 waypoints can be memorized: W00 to W99. Each time a waypoint is selected, the direction, speed and distance needed to reach it are displayed sequentially.

Operations

Note: The display timings of the direction, speed and distance are defined by the parameters *WAY HDG*, *WAY SPE* and *WAY DIS*. Each parameter can be set from 0 to 10 seconds with a default value of 4 seconds. Please refer to “Timing display of the direction in Wxx mode: *WAY HDG*”, page 23 for more details.

To use a waypoint

- By default, W00 is displayed on the mode line.
- Press the arrows **-** **+** to select the required waypoint, from W00 to W99.
- The direction, speed and distance are displayed sequentially.

To Memorize a waypoint while sailing

- Press the arrows **-** **+** to select the waypoint (from W00 to W99) that you want to overwrite.
- Press  to memorize the current boat position into the selected waypoint.
- The direction, speed and distance to reach it are displayed sequentially.

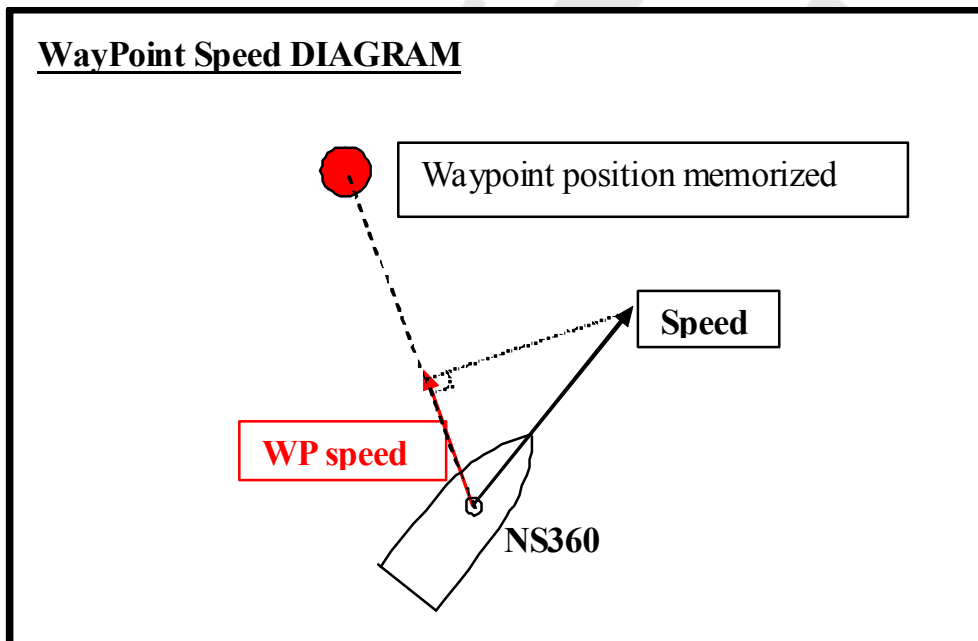

The waypoint speed displayed in knots is calculated using the waypoint position, the boat position, the boat speed and the heading.







Mode WAY

The **WAY** mode allows waypoints in your *NS360+* to be memorized with a name (3 characters) and the geographical coordinates.

To enter the WAY mode:

- Press the lower screen  and  simultaneously. “WAY” is displayed on the data line of the upper screen.
- The waypoint number and name are displayed in the mode lines of the upper screen.
- The geographical coordinates are displayed in the lower screen.
- To exit this mode, press .

How to input the name and coordinates of a waypoint

- The buttons   allow the value from 0 to 9 for numbers and from 'a' to 'z' for letters to be changed.
- The lower screen  switches to the next character.
- The upper screen  switches to the previous character.

Memorization of a waypoint

- Select first the number of the waypoint: W00 to W99
- Enter a name of 3 characters.
- Select 'NOR' (North) if the longitude is in the northern hemisphere or 'SOU' (South) if it is in the southern hemisphere.
- Memorize the longitude coordinate: for example 45'36.222.
- Select 'EAS' if the latitude is east or 'WES' if west.
- Memorize the latitude coordinate. example: 23'46.345
- When the latitude coordinate is completed, it rolls back to the selection of the waypoint number.

Advanced Operations





SET mode

The **SET** mode allows the adjustment of your *NS360+* parameters sequentially as follows:

- Display timings of the direction, speed and distance in waypoint mode
- Magnetic variation
- Device installation offset between the boat and the *NS360+*
- Boat offset
- Exit mode of the timer
- Exit mode of the start line
- Bar graph activation: on/off
- GPS module activation: on/off
- Reset the product to the factory default values
- Compass calibration

Note: GPS functions can be turned off if your sailing class does not allow them. OFF is displayed when you select any mode using the GPS functions.

To enter the SET mode:

- Make sure the device is turned OFF. Press the upper  button first and then  simultaneously. “SET” is displayed on the data line of the upper screen.
- Each parameter is displayed on the mode line of the upper line.
- You can select the required value for each parameter using the arrows  .
- Press  to memorize the parameter value and switch to the next parameter.
- You exit the **SET** mode automatically after the last parameter is memorized.

Note: Each parameter is memorized when  is pressed and before the next parameter is displayed, except for reset and calibration.

Advanced Operations

Name	Display	Description
Advanced functions ON/OFF	ADV FCT	ON: all modes are enabled (default) OFF: simple user interface enabled with SPE/TIM MH/SLD only
Timing display of the direction	WAY HDG	Timing display of the direction in waypoint mode. (0 to 10 seconds)
Timing display of the speed	WAY SPE	Timing display of the speed in waypoint mode. (0 to 10 seconds)
Timing display of the distance	WAY DIS	Timing display of the distance in waypoint mode. (0 to 10 seconds)
magnetic Variation	MAG VAR	This allows for compensation of the magnetic deviation. The default value is 0
Device installation offset	DEV OFS	Angle between the boat and the <i>NS360+</i>
Boat offset	BOA OFS	This is the length between the front of the boat and the <i>NS360+</i> Default value 0, can be adjusted in 0.1 meter increments.
Exit timer mode	EXI TIM	Default alternate mode is the speed mode. All other modes can be selected
Exit start line mode	EXI SLD	Default alternate mode is the magnetic heading mode. All other modes can be selected

Advanced Operations

LCD contrast level	LCD CON	- level 1 to 7 (default level: 5)
Bar graph activation	BAR GRA MOD	- ON (default value) - OFF
Bar graph segment resolution	BAR GRA RES	- 1 to 5 degrees, adjustable
GPS activation	GPS	- ON - OFF (if your sailing class does not allow it during races)
Firmware version	VER	Firmware version number
Reset to factory default values	RES	- ON to retrieve factory values - OFF by default
Compass calibration	CAL	- ON to start - OFF by default

The *NS360+* will automatically exit the SET mode upon completion of all parameters.

Note: You can also exit the SET mode anytime by switching off and on the product.

Advanced or simple user interface selection: ADV FCT

When 'OFF' is selected only speed/timer and heading/start line distance are accessible on the upper and the lower line (simple user interface). When 'ON' is selected (default value), all modes are available.

Timing display of the direction in Wxx mode: WAY HDG

In **Wxx** mode, the *NS360+* displays the direction, speed and distance sequentially to reach a selected waypoint. The timing display of the direction, from 0 to 10 seconds, is defined by the parameter WAY HDG. If the value 0 is selected, then the direction is not displayed at all. The default value is 4 seconds.

Timing display of the speed in Wxx mode: WAY SPE

In **Wxx** mode, the *NS360+* displays the direction, speed and distance sequentially to reach a selected waypoint. The display timing of the speed, from 0 to 10 seconds, is defined by the parameter WAY SPE. If the value 0 is selected, then the speed is not displayed at all. The default value is 4 seconds.

Timing display of the distance in Wxx mode: WAY DIS

In **Wxx** mode, the *NS360+* displays the direction, speed and distance sequentially to reach a selected waypoint. The display timing of the distance, from 0 to 10 seconds, is defined by the parameter WAY DIS. If the value 0 is selected, then the distance is not displayed at all. The default value is 4 seconds.





Angle of magnetic variation/declination: MAG VAR

Because the angle of variation varies with respect to the geographic position, the *NS360+* must be adjusted according to the specific location to achieve the maximum accuracy and synchronization between the GPS unit and the magnetic compass. The angle of variation is the actual angle observed between the true north geographic position and the actual magnetic north position.

To compensate for the magnetic variation, you need to adjust the parameter **MAG VAR** (Magnetic Variation) as follows:

- Switch off your *NS360+*

Advanced Operations

- Press the upper **mode** button first and then  simultaneously. 'SET' is displayed on the upper line of the display.
- MAG VAR is displayed on the mode line of the upper screen
- Use the arrows   to enter the required variation corrective value. The first digit will display 'W' or 'E' for a west or east variation, and the remaining 2 digits are the actual angle, adjustable from 0 to 45 degrees.
- Press  to store the value, DEV OFS (Device Offset) is now displayed.
- Go through all the parameters to exit the SET mode or press and hold  for more than 4 seconds until the device turns off.

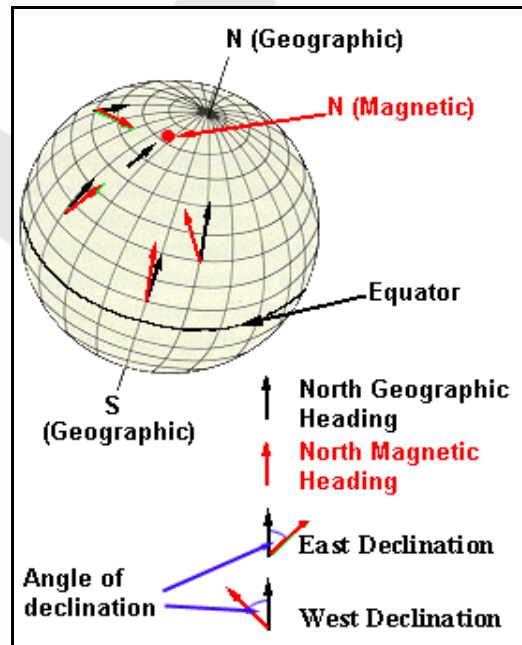

There are a number of resources available on the web that compute angles of variation for any location in the world. A “World Magnetic Model Calculator” is available from both the National Geophysical Data Center and the British Geological Survey:

- <http://www.ngdc.noaa.gov/seg/geomag/jsp/struts/calcDeclination>
- http://www.geomag.bgs.ac.uk/gifs/wmm_calc.html

Here are some examples of magnetic variation for different geographic locations:

- Hong Kong: 2 degrees west
- Melbourne: 11 degrees east
- Marseille: 0 degrees
- San Francisco: 14 degrees east

Device offset: DEV OFS







If your *NS360+* isn't facing the same direction as the boat, you can compensate this difference with the parameter 'DEV OFS' (Device Offset). This angle can be set between -179 and 180 degrees. The default value is 0.

Example: Your *NS360+* is placed starboard, facing 20 degrees off the boat heading; you need to enter Rig 20 (Right 20).

Boat offset: BOA OFS

The boat offset corresponds to the distance from the front of the boat to the *NS360+*. The remaining distance to the start line is calculated taking the boat offset and the current magnetic heading into account. The default value is 0, the maximum value is 99.9 meters and the increment is 0.1 meter.

Example: The real distance between the front of the boat to the *NS360+* is 3.2 meters. You need to enter a boat offset equal to 3.2 meters. Then, considering that the *NS360+* is 10 meters from the line, when you face the start line, the displayed remaining distance is equal to the 10-3.2 meters, 6 meters. However, using the magnetic heading of the boat, if you sail parallel to the line, the display value is equal to the real distance between the line and the *NS360+*: 10 meters.







- Switch off your *NS360+*.
- Press the upper  button first and then  simultaneously. 'SET' is displayed on the data line of the upper screen .
- Press  until BOA OFS (Boat Offset) is displayed on the mode line of the lower screen.
- Use the arrows   to enter the length between the front of the boat to your *NS360+*.
- Press  to store the value, EXI TIM (Exit mode of the Timer) is now displayed.

Advanced Operations

- Go through all the parameters to exit the SET mode or press and hold  for more than 4 seconds until the device turns off.

Exit Timer mode: EXI TIM

After the start, the timer mode is not needed anymore, for this reason the *NS360+* will switch automatically to the desired exit mode by simply setting the parameter EXI TIM (Exit Timer mode) as follows:







- Switch off your *NS360+*.
- Press the upper  button first and then  simultaneously. 'SET' is displayed on the data line of the upper screen.
- Press  until EXI TIM (Exit Timer mode) is displayed on the data line of the lower screen.
- Use the arrows   to select the desired exit mode for your *NS360+*.
- Press  to store the value, EXI SLD is now displayed.
- Go through all the parameters to exit the SET mode or press and hold  for more than 4 seconds until the device turns off.

Note: Only a mode (SPE, HDG, WIN, TIM, SLD, Wxx) and not a sub-mode (Hi, Md, Lo, TRP, VMG, Rol, W01 etc) can be memorized in the EXI TIM parameter. However, the timer will switch automatically to the memorized mode and the sub-mode that you are currently using.

Note: The mode by default is SPE (Speed mode).

Exit mode of the Start Line: EXI SLD

After the start, the start line distance (SLD) mode is not needed anymore, for this reason the *NS360+* will switch automatically to the desired exit mode by simply setting the parameter 'EXI SLD' (Exit mode of the Start Line) as follows:

- Switch off your *NS360+*.
- Press the upper **mode** button first and then  simultaneously. 'SET' is displayed on the data line of the upper screen.
- Press  until EXI SLD (Exit mode of the Start Line) is displayed on the data line of the lower screen.
- Use the arrows   to select the desired exit mode for your *NS360+*.
- Press  to store the value, GPS (GPS function parameter) is now displayed.
- Go through all the parameters to exit the SET mode or press and hold  for more than 4 seconds until the device turns off.

Note: Only a mode (SPE, HDG, WIN, TIM, SLD, Wxx) and not a sub-mode (Hi, Md, Lo, TRP, VMG, Rol, W01 etc) can be memorized in the EXI SLD parameter. However, the SLD mode will switch automatically to the memorized mode and the sub-mode that you are currently using.

Note: The mode by default is HDG (Magnetic Heading mode).

LCD contrast adjustment: LCD CON

The LCD contrast level can be set from 1 to 7 (the level 5 default value is applied when the SET mode is entered).

Enable or disable the bar graph: BAR GRA MOD

To disable this function simply select the 'OFF' parameter ('ON' by default).

Bar graph resolution: BAR GRA RES

This parameter allows the resolution of each segment of the bar graph to be defined from 1 to 5 degrees. The default value is 3 degrees.

Advanced Operations

Enable or disable the GPS functions: GPS



If your boat class does not allow electronic navigation aids and/or a speedometer, you are required to switch off all the functions issued with the embedded GPS module. When the GPS feature is turned off, the battery life is increased to approximately 200 hours. To check more details of the functions affected when switching off the GPS module, please refer to the table 1: GPS functions activation.

Table 1: GPS functions activation

	GPS Off
Speed: SPE (Hi/ Md/ Lo/ TRP/ VMG)	Off
Magnetic Heading: HDG (Hi/ Md/ Lo/ RoI)	On
Wind Shift Indicator: WIN	On
Timer: TIM	On
Start Line Distance: SLD	Off
Waypoint: Wxx (W00/ W01/ .../W99)	Off

Note: During normal usage, if you select a mode which has been disabled by setting off the GPS functions, then 'OFF' will be displayed on the screen.

Firmware version: VER

The firmware version is displayed (for example: 1.0). The values displayed on the sub-mode of the lower line are factory settings that should not be modified. If changed by mistake, please return to the values '050' and '010' (reading from top to bottom) by using the arrows   and the top and bottom  buttons.

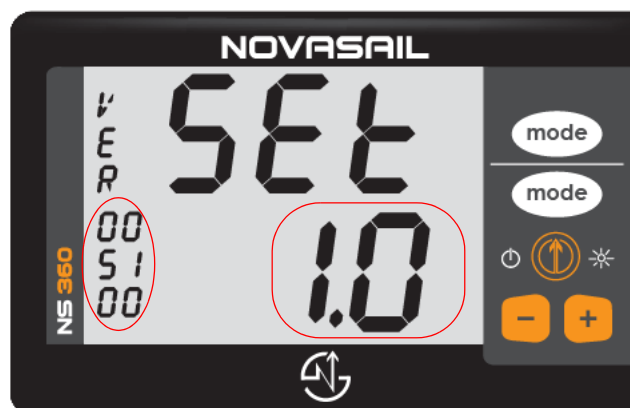

RESet to factory compass calibration values: RES

When set to ON and when the select key is pushed, the default factory calibration values of the compass are restored and the *NS360+* is powered off automatically.

Calibration

User CALibration of the magnetic compass: CAL

When set to ON and when the select key is pushed, the *NS360+* enters a set of sub-menus to allow a self calibration of the magnetic compass. There are 10 sub-menus that have to be followed in the sequence described below.

To allow the maximum accuracy of the calibration procedure, it is recommended to perform this outdoors to avoid any magnetic disturbing fields. A wooden surface is highly recommended (eg a table) and it is necessary to ensure that there are no ferrous materials nearby (wrist watches should be removed).

To start with draw 2 perpendicular lines (X and Y axis) on a perfectly horizontal plan. On the lower screen of the display, the calibration sub-menu number is displayed. There are 10 steps to follow in order to complete the calibration of your *NS360+*. Upon completion of the sequence, the *NS360+* will memorize the new values and shut down automatically. If the *NS360+* is shut down during the calibration, nothing will be memorized.

Note: Whenever necessary, the factory calibration values can be restored at any time by setting the RES menu to ON in the SET mode.

- Step 1: '1' is displayed on the lower screen. The *NS360+* must be oriented as follows:

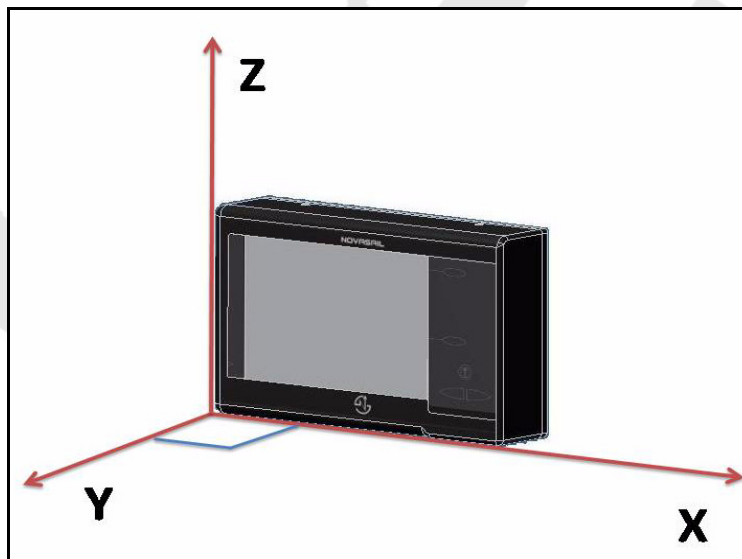

Push the select key when ready. The *NS360+* will enter the calibration along the axis. After a few seconds, 3 beeps will be emitted to notify the end of step 1.

- Step 2: '2' is now displayed on the lower screen. The *NS360+* must be oriented as follows:

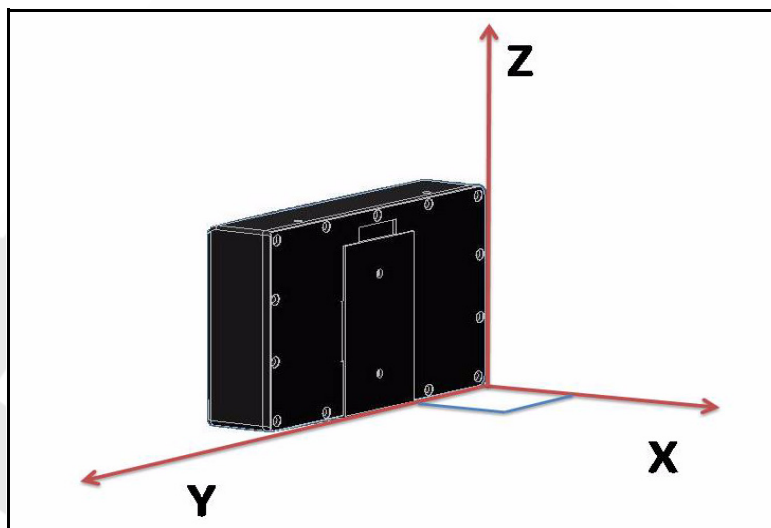

Push the select key when ready. The *NS360+* will enter the calibration along the axis. After a few seconds, 3 beeps will be emitted to notify the end of step 2.

- Step 3: '3' is now displayed on the lower screen. The *NS360+* must be oriented as follows:

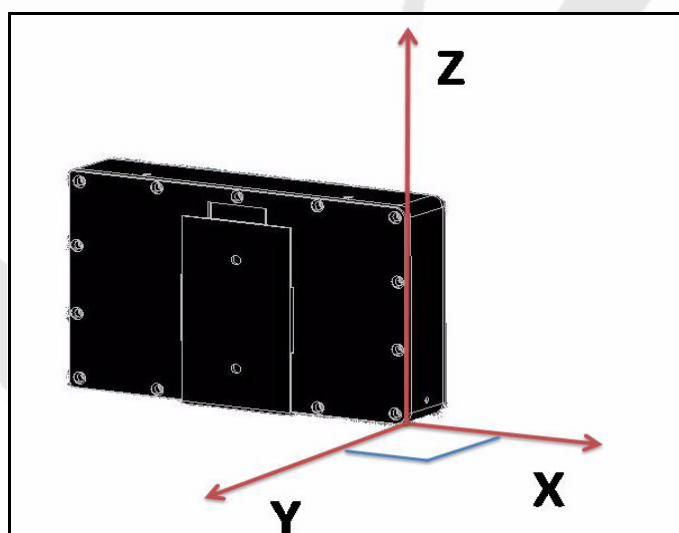

Push the select key when ready. The *NS360+* will enter the calibration along the axis. After a few seconds, 3 beeps will be emitted to notify the end of step 3.

Calibration

- Step 4: '4' is now displayed on the lower screen. The *NS360+* must be oriented as follows:

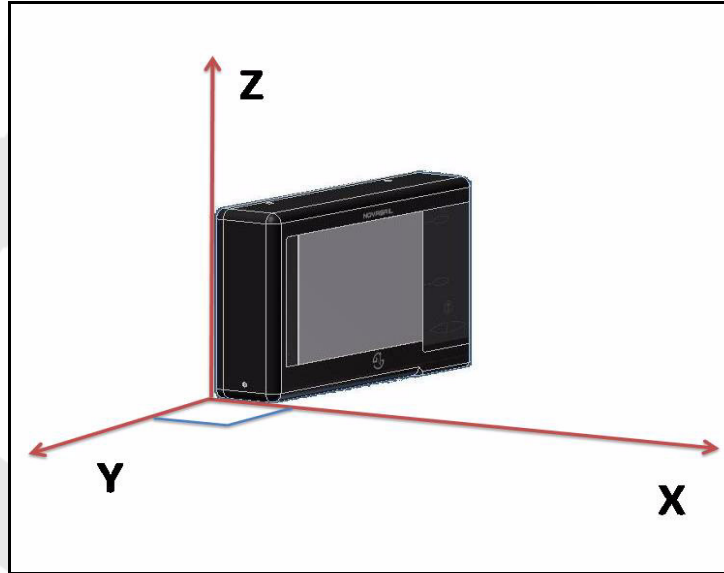

Push the select key when ready. The *NS360+* will enter the calibration along the axis. After a few seconds, 3 beeps will be emitted to notify the end of step 4.

- Step 5: '5' is now displayed on the lower screen. The *NS360+* must be oriented as follows:

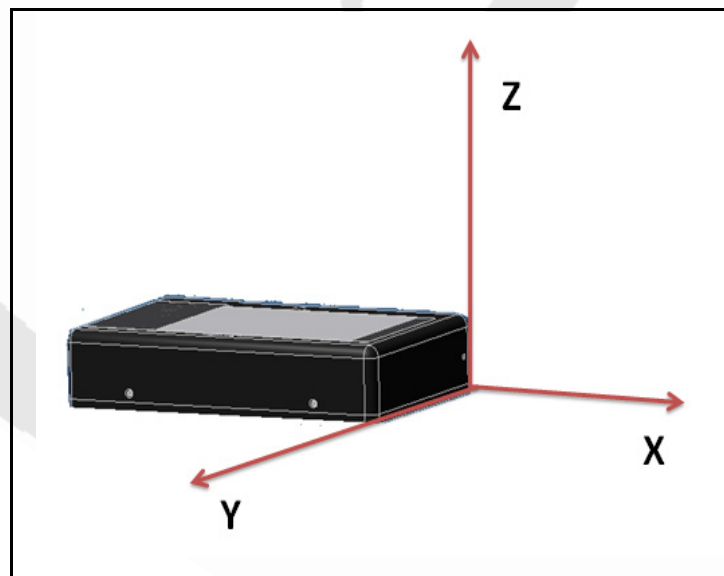

Push the select key when ready. The *NS360+* will enter the calibration along the axis. After a few seconds, 3 beeps will be emitted to notify the end of step 5.

- Step 6: '6' is now displayed on the lower screen. The *NS360+* must be oriented as follows:

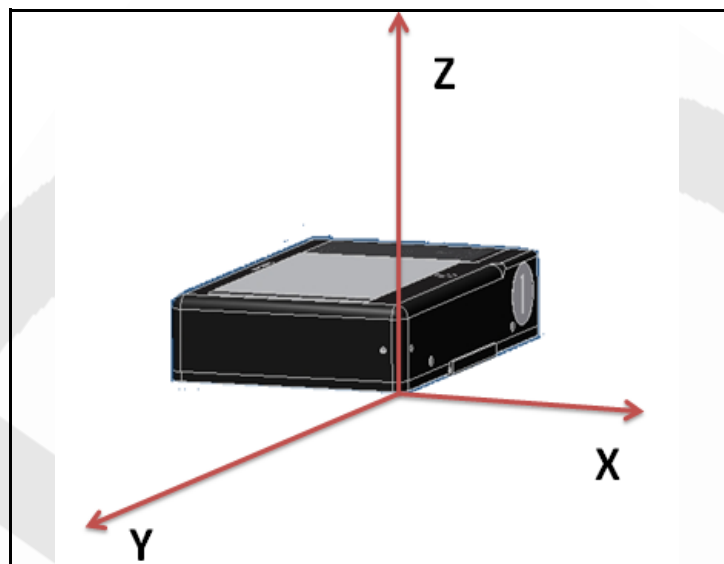

Push the select key when ready. The *NS360+* will enter the calibration along the axis. After a few seconds, 3 beeps will be emitted to notify the end of step 6.

- Step 7: '7' is now displayed on the lower screen. The *NS360+* must be oriented as follows:

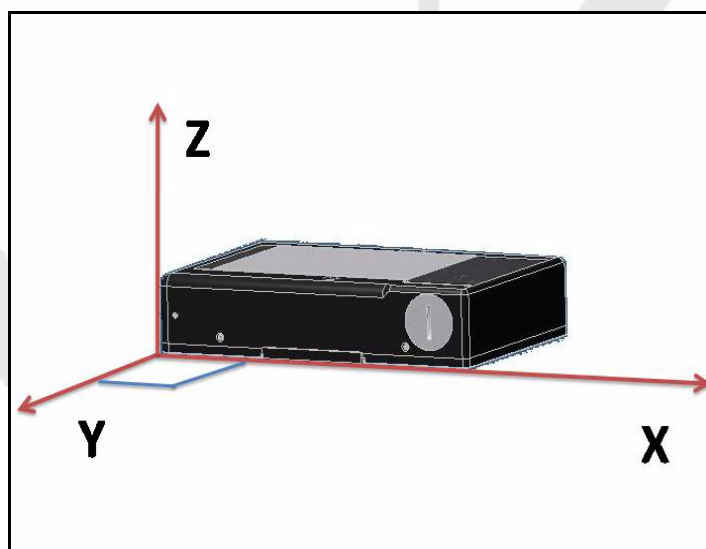

Push the select key when ready. The *NS360+* will enter the calibration along the axis. After a few seconds, 3 beeps will be emitted to notify the end of step 7.

Calibration

- Step 8: '8' is now displayed on the lower screen. The *NS360+* must be oriented as follows:

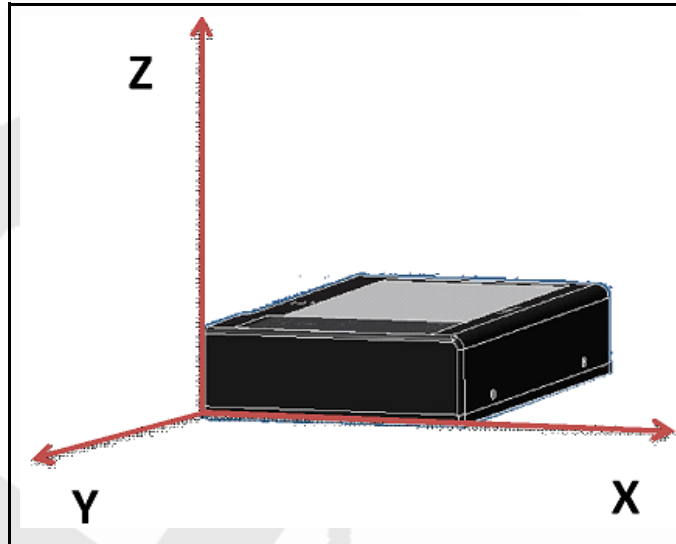

Push the select key when ready. The *NS360+* will enter the calibration along the axis. After a few seconds, 3 beeps will be emitted to notify the end of step 8.

- Step 9: '9' is now displayed on the lower screen. The *NS360+* must be oriented as follows:

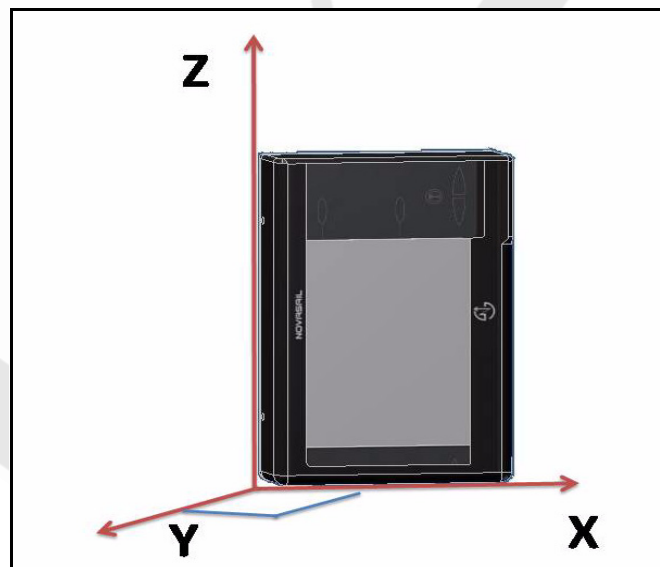

Push the select key when ready. The *NS360+* will enter the calibration along the axis. After a few seconds, 3 beeps will be emitted to notify the end of step 9.

- Step 10: '10' is displayed on the lower screen. The *NS360+* must be oriented as follows:

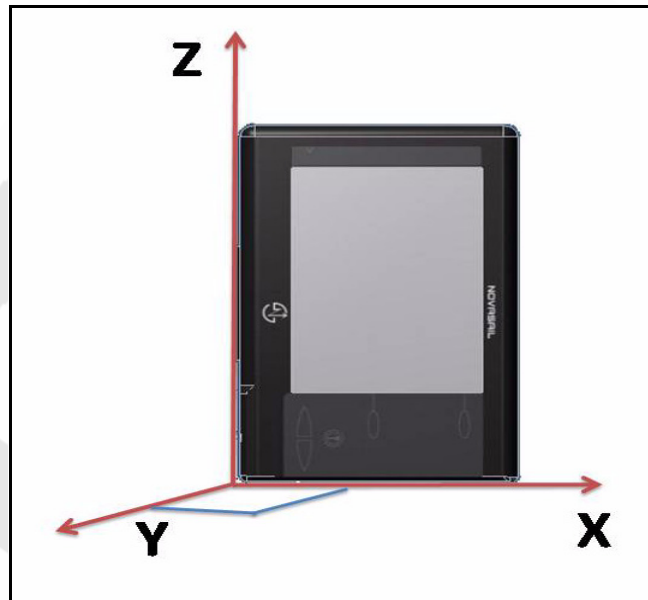

Push the select key when ready. The *NS360+* will enter the calibration along the axis. After a few seconds, 3 beeps will be emitted to notify the end of step 10.

The *NS360+* will store the new values and switch off automatically.

Document history

Version 1.0: First version

Version 1.1: 06/2011

Added 'ADV FCT' description in the setup mode (firmware 1.2 and above)

Modified SLD mode description

Limited warranty

This product meets or exceeds all of Novasail's rigorous quality controls and inspection standards. Complete services will be provided in accordance with the statement of warranty set forth below if any manufacturing defect or natural failure occurs within the warranty period.

Warranty Terms and Conditions

- If any defect arises under normal conditions of use within the warranty period, our customer service center or specified partner will provide the required repair services at no charge, or legally applicable services according to the appropriate consumer protection laws and regulations of the country in which the product was purchased by the warranty holder.
- The product has to be registered using the online service available on the Novasail web site: www.nova-sail.com
- Please submit the proof of purchase (invoice) when requesting service.
- The actual cost of repair may be charged to the customer or the performance of warranty service may be rendered impossible, even within the warranty period, under the following circumstances:
 - Product failure caused by accident or carelessness
 - Disassembly or modification for purposes other than it was originally intended for
 - Failure caused by a fire, earthquake or flood
 - Damage/failure caused by an impact
 - Failure caused by inappropriate services performed by anyone other than Novasail's customer service center or one of Novasail's service specified partners
- For assistance please contact Novasail service center:

E-mail: contact@nova-sail.com
www.nova-sail.com

DISCLAIMER

Information in this document is provided solely in connection with NOVASAIL LTD products. NOVASAIL LTD reserves the right to make changes, corrections, modifications or improvements to this document and the products described herein at any time, without notice.

All NOVASAIL LTD products are sold pursuant to NOVASAIL LTD's terms and conditions of sale.

Purchasers are solely responsible for the choice, selection and use of the NOVASAIL LTD products described herein, and NOVASAIL LTD assumes no liability whatsoever relating to the choice, selection or use of the NOVASAIL LTD products described herein.

UNLESS OTHERWISE SET FORTH IN NOVASAIL LTD'S TERMS AND CONDITIONS OF SALE, NOVASAIL LTD DISCLAIMS ANY EXPRESS OR IMPLIED WARRANTY WITH RESPECT TO THE USE AND/OR SALE OF NOVASAIL LTD PRODUCTS, INCLUDING WITHOUT LIMITATION IMPLIED WARRANTIES OF MERCHANTABILITY OR FITNESS FOR A PARTICULAR PURPOSE (AND THEIR EQUIVALENTS UNDER THE LAWS OF ANY JURISDICTION).

UNLESS EXPRESSLY APPROVED IN WRITING BY AN AUTHORIZED NOVASAIL LTD REPRESENTATIVE, NOVASAIL LTD PRODUCTS ARE NOT RECOMMENDED, AUTHORIZED OR WARRANTED FOR USE IN MILITARY, AIR CRAFT, SPACE, LIFE SAVING, OR LIFE SUSTAINING APPLICATIONS, NOR IN PRODUCTS OR SYSTEMS WHERE FAILURE OR MALFUNCTION MAY RESULT IN PERSONAL INJURY, DEATH, OR SEVERE PROPERTY OR ENVIRONMENTAL DAMAGE.

Resale of NOVASAIL LTD products with provisions different from the statements and/or technical features set forth in this document shall immediately void any warranty granted by NOVASAIL LTD for the NOVASAIL LTD product or service described herein and shall not create or extend in any manner whatsoever, any liability of NOVASAIL LTD.





© 2011 NOVASAIL - All rights reserved
www.nova-sail.com